



Coupling Selection Guide

Just because applications have the same horsepower, doesn't mean they require the same size flexible coupling. If you follow these simple steps, you can basically find the flexible coupling in the following coupling data table that's perfect for your application.

Step 1. Determine the Service Factor

Motors with the same horsepower are assigned different service factors to reflect the different loads and stresses. For example, a 40HP motor running a standard hydraulic application with infrequent stops carries a service factor of 1.00 while another 40HP application on an injection molding machine has a service factor of 3.00. This means the second motor requires a larger flexible coupling than the first. Ignoring the service factor can cause you to use a coupling too small for your application, leading to premature wear and maintenance.

For applications with intermittent starts and stops and no reversing, a 1.50 to 1.75 service factor would be appropriate. Applications with frequent starts and stops or reversing duty normally carry a 2.00 service factor. Typically, motors designed for high torque or reversing applications have a 3.00 service factor. Service factors for other typical applications include:

Application	Service Factor
Hydraulic applications with infrequent stops	1.00 to 1.50
Hydraulic units with cycling loads	1.50 to 2.50
Conveyors	1.50 to 2.50
Internal combustion engines	1.75 to 2.50
Machine tool, Textile, Cranes and Woodworking Machinery	2.0
Saw mill machines	3.0
Injection molding machines	3.0

Note: The standard P380 insert is rated for service factors up to 1.50. For applications rated above 1.50 the Hytrel insert is recommended.

Bore and Keyway Example

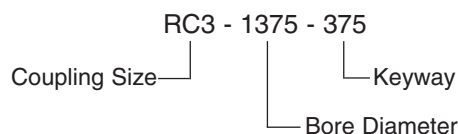

Step 2. Determine minimum torque rating in lbs.-in

If the minimum torque rating is not known, it can be calculated using the HP and RPM

$$\text{Minimum torque} = (\text{HP} \times 63000) / \text{RPM}$$

Step 3. Multiply full load torque by the selected service factor

Step 4. Determine shaft size

A shaft diameter must not exceed a coupling's maximum bore. For example, Reuland's RC3 Flexible Coupling has a 1 1/8" maximum bore (shaft diameter). Therefore, 1 1/8" is the largest shaft that can be installed in the coupling.

Step 5. Go to the coupling data table

Select the coupling size that meets or exceeds your minimum torque and service factor calculations. Then go to the coupling standard bore and key availability chart to match the bore and key. (Ensure the motor shaft does not exceed the coupling's maximum bore).

Part Numbers

Reuland's part numbering system is based on the coupling's size, bore diameter and key size or spline. The first three digits represent the Reuland Coupling size. The next four digits reference the bore diameter or number of teeth/pitch (in inches or millimeters). The last grouping indicates keyway, clamp or spline options.

Spline Example

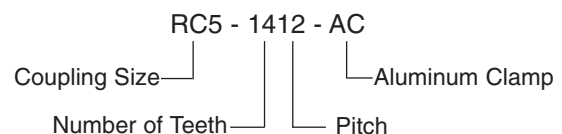

Specifications subject to change without notice

Coupling Data Table

Size	Dimensions (inches)			Distance Between Shafts (inches)		Maximum Bore (inches)	Rated Torque LB.In.	Rated Horsepower				Inertia LB-FT ²	Insert
	A	B	C	D(Min)	E(Max)			F	@100 RPM	@1200 RPM	@1800 RPM		
	RC1	2.62	2.56			2.12	.06		0.75	1.125	473 630	0.75 1	9 12
RC2	2.91	3.17	2.31	.06	0.88	1.375	630 1103	1 1.75	12 21	18 31.5	36 63	0.009	P380 Hytrel
RC3	3.44	3.60	2.97	.06	0.88	1.625	1261 2206	2 3.5	24 42	36 63	72 126	0.022	P380 Hytrel
RC4	4.00	4.24	3.12	.06	1.12	1.875	1576 3309	2.5 5.25	30 63	45 94.5	90 189	0.039	P380 Hytrel
RC5	4.81	4.68	4.06	.06	1.25	2.375	3466 6933	5.5 11	66 132	99 198	198 396	0.100	P380 Hytrel
RC6	5.97	6.04	4.56	.06	1.38	2.625	7563 15756	12 25	144 300	216 450	432 900	0.260	P380 Hytrel
RC7	6.91	7.01	5.25	.06	1.88	2.875	12605 28361	20 45	240 540	360 810	720 1620	0.480	P380 Hytrel
RC8	8.62	7.92	7.12	.06	2.00	3.875	31513 47269	50 75	600 900	900 1350	1800 2700	1.560	P380 Hytrel

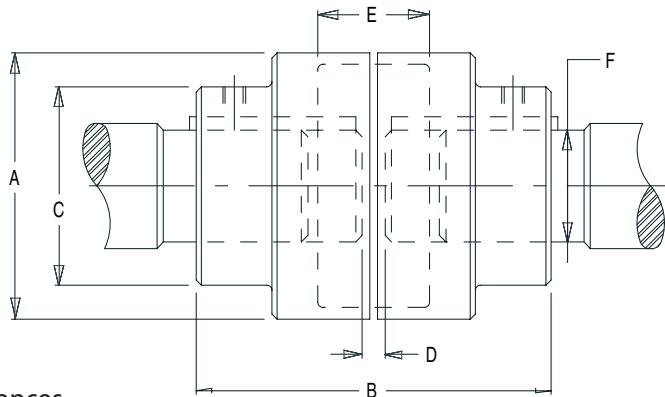

Bore Tolerances

Nominal Bore Diameter		
From	To (including)	Tolerance
.375	1.000	+0.0008/+0.0003
1.000	2.000	+0.0013/+0.0005
2.000	3.000	+0.0018/+0.0008
3.000	3.875	+0.0020/+0.0010

Insert Specifications

Insert Type	Temperature Range	Misalignment		Characteristics
		Angular (degrees)	Parallel (inches)	
P380	-30°F to 175°F	1°	.015	Good for moderate cyclic loading, offers good oil and chemical resistance, misalignment and dampening capacity.
Hytrel	-60°F to 250°F	1/2°	.015	Recommended for severe duty applications. Excellent oil and chemical resistance. Torsionally stiffer than P380.

Spline Coupling Availability

Spline Specifications		
Number Teeth	Pitch	Coupling Availability
9	16/32	RC1 - RC5
13	8/16	RC4 - RC8
13	16/32	RC1 - RC6
14	12/24	RC2 - RC8
15	8/16	RC4 - RC8
15	16/32	RC1 - RC6
17	12/24	RC3 - RC8
21	16/32	RC3 - RC8
21	16/32	RC3 - RC8
23	16/32	RC3 - RC8
27	16/32	RC4 - RC8

Part Number for Inserts

Coupling Size	Insert Type	
	P380	Hytrel
RC1	RG1P9	RG1H5
RC2	RG2P9	RG2H5
RC3	RG3P9	RG3H5
RC4	RG4P9	RG4H5
RC5	RG5P9	RG5H5
RC6	RG6P9	RG6H5
RC7	RG7P9	RG7H5
RC8	RG8P9	RG8H5

Standard Inch Bore Jaw Couplings

Bore	Keyway	RC1	RC2	RC3	RC4	RC5	RC6	RC7	RC8
3/8"	3/32"	RC1-0375-093	RC2-0375-093						
7/16"	3/32"	RC1-0437-093	RC2-0437-093						
7/16"	1/8"	RC1-0437-125	RC2-0437-125						
1/2"	1/8"	RC1-0500-125	RC2-0500-125	RC3-0500-125					
9/16"	1/8"	RC1-0562-125	RC2-0562-125	RC3-0562-125					
5/8"	5/32"	RC1-0625-156	RC2-0625-156	RC3-0625-156					
5/8"	3/16"	RC1-0625-187	RC2-0625-187	RC3-0625-187	RC4-0625-187				
11/16"	3/16"	RC1-0687-187	RC2-0687-187	RC3-0687-187	RC4-0687-187				
3/4"	1/8"	RC1-0750-125	RC2-0750-125	RC3-0750-125	RC4-0750-125				
3/4"	3/16"	RC1-0750-187	RC2-0750-187	RC3-0750-187	RC4-0750-187	RC5-0750-187	RC6-0750-187		
7/8"	3/16"	RC1-0875-187	RC2-0875-187	RC3-0875-187	RC4-0875-187	RC5-0875-187	RC6-0875-187		
7/8"	1/4"	RC1-0875-250	RC2-0875-250	RC3-0875-250	RC4-0875-250	RC5-0875-250	RC6-0875-250		
15/16"	1/4"	RC1-0937-250	RC2-0937-250	RC3-0937-250	RC4-0937-250	RC5-0937-250	RC6-0937-250		
1"	3/16"	RC1-1000-187	RC2-1000-187	RC3-1000-187	RC4-1000-187	RC5-1000-187	RC6-1000-187		
1"	1/4"	RC1-1000-250	RC2-1000-250	RC3-1000-250	RC4-1000-250	RC5-1000-250	RC6-1000-250		
1 1/8"	1/4"	RC1-1125-250	RC2-1125-250	RC3-1125-250	RC4-1125-250	RC5-1125-250	RC6-1125-250	RC7-1125-250	
1 3/16"	1/4"		RC2-1187-250	RC3-1187-250	RC4-1187-250	RC5-1187-250	RC6-1187-250	RC7-1187-250	
1 1/4"	1/4"		RC2-1250-250	RC3-1250-250	RC4-1250-250	RC5-1250-250	RC6-1250-250	RC7-1250-250	RC8-1250-250
1 1/4"	5/16"		RC2-1250-312	RC3-1250-312	RC4-1250-312	RC5-1250-312	RC6-1250-312	RC7-1250-312	RC8-1250-312
1 3/8"	5/16"		RC2-1375-312	RC3-1375-312	RC4-1375-312	RC5-1375-312	RC6-1375-312	RC7-1375-312	RC8-1375-312
1 3/8"	3/8"		RC2-1375-375	RC3-1375-375	RC4-1375-375	RC5-1375-375	RC6-1375-375	RC7-1375-375	RC8-1375-375
1 7/16"	3/8"			RC3-1437-375	RC4-1437-375	RC5-1437-375	RC6-1437-375	RC7-1437-375	RC8-1437-375
1 1/2"	5/16"			RC3-1500-312	RC4-1500-312	RC5-1500-312	RC6-1500-312	RC7-1500-312	RC8-1500-312
1 1/2"	3/8"			RC3-1500-375	RC4-1500-375	RC5-1500-375	RC6-1500-375	RC7-1500-375	RC8-1500-375
1 5/8"	3/8"			RC3-1625-375	RC4-1625-375	RC5-1625-375	RC6-1625-375	RC7-1625-375	RC8-1625-375
1 3/4"	3/8"				RC4-1750-375	RC5-1750-375	RC6-1750-375	RC7-1750-375	RC8-1750-375
1 3/4"	7/16"				RC4-1750-437	RC5-1750-437	RC6-1750-437	RC7-1750-437	RC8-1750-437
1 7/8"	1/2"				RC4-1875-500	RC5-1875-500	RC6-1875-500	RC7-1875-500	RC8-1875-500
1 15/16"	1/2"					RC5-1937-500	RC6-1937-500	RC7-1937-500	RC8-1937-500
2"	1/2"					RC5-2000-500	RC6-2000-500	RC7-2000-500	RC8-2000-500
2 1/8"	1/2"					RC5-2125-500	RC6-2125-500	RC7-2125-500	RC8-2125-500
2 1/4"	1/2"					RC5-2250-500	RC6-2250-500	RC7-2250-500	RC8-2250-500
2 3/8"	5/8"					RC5-2375-625	RC6-2375-625	RC7-2375-625	RC8-2375-625
2 1/2"	5/8"						RC6-2500-625	RC7-2500-625	RC8-2500-625
2 5/8"	5/8"						RC6-2625-625	RC7-2625-625	RC8-2625-625
2 3/4"	5/8"							RC7-2750-625	RC8-2750-625
2 7/8"	3/4"							RC7-2875-750	RC8-2875-750
3"	3/4"								RC8-3000-750
3 1/4"	3/4"								RC8-3250-750
3 3/8"	7/8"								RC8-3375-875
3 1/2"	7/8"								RC8-3500-875
3 5/8"	7/8"								RC8-3625-875
3 3/4"	7/8"								RC8-3750-875
3 7/8"	1"								RC8-3875-100

Specifications subject to change without notice

2 Bolt Mounting Flanges

Mounting Flange			Pilot Dimensions	Flange Dimensions	
SAE	USA	ANSI	A	K	M
AA	-	50-2	2.000-1.998	3.255 3.245	0.406
A	-	82-2	3.250-3.248	4.192 4.182	0.437
B	-	101-2	4.000-3.998	5.755 5.745	0.563
C	-	127-2	5.000-4.998	7.130 7.120	0.688
D	-	152-2	6.000-5.998	9.005 8.995	0.813
E	-	165-2	6.500-6.498	12.505 12.495	1.063
F	-	177-2	7.000-6.998	13.786 13.776	1.063

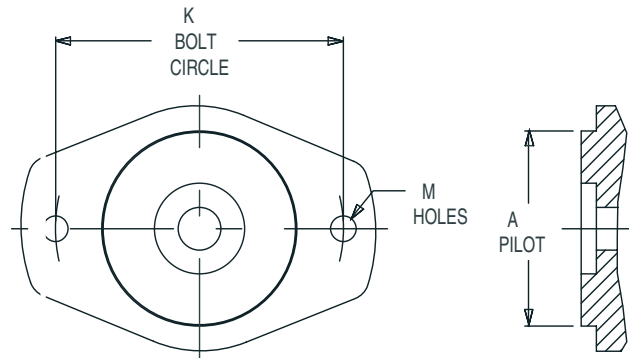

4 Bolt Mounting Flanges

Mounting Flange			Pilot Dimensions	Flange Dimensions	
SAE	USA	ANSI	A	S	R
-	4F17	-	1.781-1.799	2.843 2.833	0.375
B	4F40	101-4	4.000-3.998	5.005 4.995	0.563
C	4F50	127-4	5.000-4.998	6.380 6.370	0.563
D	4F60	152-4	6.000-5.998	9.005 8.995	0.813
E	4F65	165-4	6.500-6.498	12.505 12.495	0.813
F	4F70	177-4	7.000-6.998	13.786 13.776	1.063

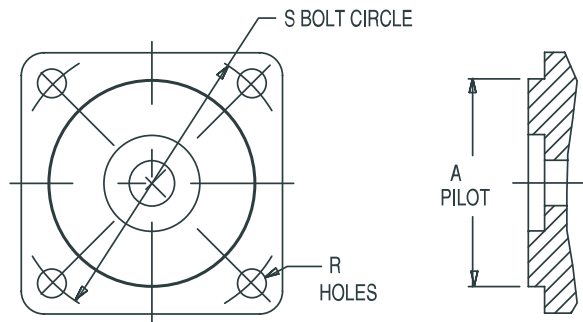

2 Bolt 45° Offset Mounting Flanges

Mounting Flange			Pilot Dimensions	Flange Dimensions	
SAE	USA	ANSI	A	K	M
A45°	2F32 (45°)	82-2 (45°)	3.250-3.248	4.192 4.182	0.437
B45°	2F40 (45°)	101-2 (45°)	4.000-3.998	5.755 5.745	0.563
C45°	2F50 (45°)	125-2 (45°)	5.000-4.998	7.130 7.120	0.688

