



PROVIDING QUALITY PRODUCTS SINCE 1995

FLANGES



 905-545-2038

 716-283-8781

www.trilexfluidpower.com

CONTENTS

FLANGES - CARBON STEEL 3

BOLT PATTERN ADAPTERS	3
J518 SPLIT & CAPTIVE FLANGE.	4
SPLIT FLANGE ADAPTERS.	5
THREADED	6
SPLIT FLANGE ADAPTERS.	7
FLANGE HEAD X FLANGE HEAD	8
BUTT WELD FLANGE HEAD.	9
BUTT WELD FLANGE HEAD.	10
FEMALE FLANGE HEAD ADAPTER	11
TUBE FLANGE HEAD FITTING.	12
CONNECTOR BLOCK & PLATE	13
GAUGE PORT SPACER.	14
BLANKING	15
ZERO PSI SHIPPING PLATE	16
NPTF THREAD	17
SAE THREAD	18
BSPP THREAD	19
JIC THREAD	20
ORFS THREAD	21
FLAT SOCKET WELD PIPE	22
FLAT SOCKET WELD TUBE	23
DEEP SOCKET WELD PIPE.	24
DEEP SOCKET WELD TUBE	25
BUTT WELD PIPE.	26
BUTT WELD PIPE.	27
SADDLE WELD	28
NPTF TANK PILOT	29

ELBOW BLOCK.	30
TEE JUNCTION BLOCK	31
THREADED ELBOW	32
SOCKET WELD PIPE ELBOW	33
SOCKET WELD TUBE ELBOW	34
3000 SERIES SQUARE PATTERN	35
6000 SERIES SQUARE PATTERN	36
ISO 6164 SOCKETWELD FLANGES	37
FLANGE PLUG	38

FLANGES - STAINLESS STEEL 39

J518 SPLIT & CAPTIVE FLANGE.	40
SPLIT FLANGE ADAPTERS.	41
BLANKING	42
NPTF THREAD	43
SAE THREAD	44
FLAT SOCKET WELD PIPE	45
DEEP SOCKET WELD PIPE.	46
BUTT WELD PIPE.	47
BUTT WELD PIPE.	48
BUTT WELD FLANGE HEAD.	49
BUTT WELD FLANGE HEAD.	50
ELBOW BLOCK.	51
TEE JUNCTION BLOCK	52
SOCKET WELD PIPE ELBOW	53
3000 SERIES SQUARE PATTERN	54

BOLT PATTERN ADAPTERS

FLANGES -
CARBON STEEL

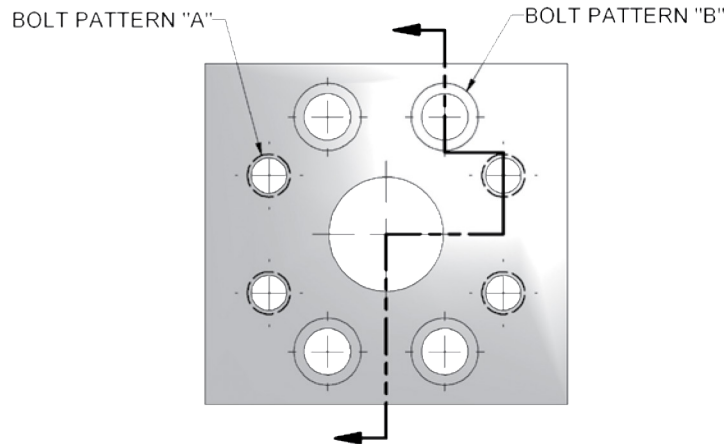

- Outer envelope shape may vary due to size configuration.
- Mounting kit available on o-ring grooved flanges by simply adding suffix letter 'U' to part number.

AFA - 1261 - 3261

AFA
Pattern A:
Flat Faced and Tapped
Pattern B:
O-Ring and Drilled

AFAC
Pattern A:
Flat Faced and Tapped
Pattern B:
Flat Faced and Tapped

**Bolt Pattern A
Bolt Pattern Size**

**Bolt Pattern A
Code 61 or
Code 62**

**Bolt Pattern B
Bolt Pattern Size**

**Bolt Pattern B
Code 61 or
Code 62**

J518 SPLIT & CAPTIVE FLANGE

FLANGES -
CARBON STEEL

CODE 61 SPLIT FLANGE

* PART NO.	† KIT PART NO.	FLANGE SIZE	A	B	C	D	E	F	G	H	J	MOUNTING HARDWARE	
												O-RING	SHCS
8SF-2	8SFO	0.50	0.86	2.12	1.500	0.75	0.50	1.219	0.955	0.245	0.350	210	5/16-18X1.25
12SF-2	12SFO	0.75	0.98	2.56	1.875	0.88	0.56	1.531	1.265	0.245	0.417	214	3/8-16X1.25
16SF-2	16SFO	1.00	1.11	2.75	2.062	0.94	0.62	1.781	1.515	0.295	0.417	219	3/8-16X1.25
20SF-2	20SFO	1.25	1.39	3.12	2.312	0.88	0.56	2.031	1.720	0.295	0.472	222	7/16-14X1.50
24SF-2	24SFO	1.50	1.58	3.69	2.750	1.00	0.62	2.406	2.000	0.295	0.524	225	1/2-13X1.50
32SF-2	32SFO	2.00	1.86	4.00	3.062	1.03	0.62	2.844	2.470	0.355	0.524	228	1/2-13X1.50
40SF-2	40SFO	2.50	2.09	4.50	3.500	1.50	0.75	3.344	2.950	0.355	0.524	232	1/2-13X1.75
48SF-2	48SFO	3.00	2.53	5.31	4.188	1.62	0.88	4.031	3.580	0.355	0.657	237	5/8-11X1.75
56SF-2	56SFO	3.50	2.70	6.00	4.750	1.12	0.88	4.531	4.030	0.422	0.657	241	5/8-11X2.00
64SF-2	64SFO	4.00	2.95	6.38	5.125	1.38	1.00	5.031	4.530	0.422	0.657	245	5/8-11X2.00

CODE 62 SPLIT FLANGE

* PART NO.	† KIT PART NO.	FLANGE SIZE	A	B	C	D	E	F	G	H	J	MOUNTING HARDWARE	
												O-RING	SHCS
8SFX-2	8SFXO	0.50	0.89	2.22	1.594	0.88	0.62	1.281	0.970	0.285	0.350	210	5/16-18X1.25
12SFX-2	12SFXO	0.75	1.14	2.81	2.000	1.12	0.75	1.656	1.280	0.325	0.417	214	3/8-16X1.50
16SFX-2	16SFXO	1.00	1.33	3.19	2.250	1.31	0.94	1.906	1.530	0.355	0.472	219	7/16-14X1.75
20SFX-2	20SFXO	1.25	1.48	3.75	2.625	1.50	1.06	2.156	1.750	0.385	0.524	222	1/2-13X1.75
24SFX-2	24SFXO	1.50	1.83	4.44	3.125	1.69	1.19	2.531	2.030	0.475	0.657	225	5/8-11X2.25
32SFX-2	32SFXO	2.00	2.20	5.25	3.812	2.06	1.44	3.156	2.660	0.475	0.811	228	3/4-10X2.75

* Trilex Fluid Power includes: (1) split flange half only

† Kit part No. includes: (2) split flange halves, (4) hex head screws with flat washers, (1) Buna N O-Ring
Split flange halves are silver trivalent plated

CODE 61 CAPTIVE FLANGE

DRILLED NO.	TAPPED PART NO.	FLANGE SIZE	A	B	C	D	E	F	G	H	J	MOUNTING HARDWARE	
												O-RING	SHCS
8SFW	8SFTW	0.50	1.81	2.12	0.688	1.500	0.75	0.50	1.219	0.955	0.245	0.344	5/16-18
12SFW	12SFTW	0.75	2.06	2.56	0.875	1.875	0.88	0.56	1.531	1.265	0.245	0.406	3/8-16
16SFW	16SFTW	1.00	2.31	2.75	1.031	2.062	0.94	0.62	1.781	1.515	0.295	0.406	3/8-16
20SFW	20SFTW	1.25	2.88	3.12	1.188	2.312	0.88	0.56	2.031	1.720	0.295	0.469	7/16-14
24SFW	24SFTW	1.50	3.25	3.69	1.406	2.750	1.00	0.62	2.406	2.000	0.295	0.531	1/2-13
32SFW	32SFTW	2.00	3.81	4.00	1.688	3.062	1.03	0.62	2.844	2.470	0.355	0.531	1/2-13
40SFW	40SFTW	2.50	4.28	4.50	2.000	3.500	1.50	0.75	3.344	2.950	0.355	0.531	1/2-13
48SFW	48SFTW	3.00	5.16	5.31	2.438	4.188	1.62	0.88	4.031	3.580	0.355	0.656	5/8-11
56SFW	56SFTW	3.50	5.50	6.00	2.750	4.750	1.12	0.88	4.531	4.030	0.422	0.656	5/8-11
64SFW	64SFTW	4.00	6.00	6.38	3.062	5.125	1.38	1.00	5.031	4.530	0.422	0.656	5/8-11

CODE 62 CAPTIVE FLANGE

DRILLED NO.	TAPPED PART NO.	FLANGE SIZE	A	B	C	D	E	F	G	H	J	MOUNTING HARDWARE	
												O-RING	SHCS
8SFXW	8SFXTW	0.50	1.86	2.22	0.718	1.594	0.88	0.62	1.281	0.970	0.285	0.344	5/16-18
12SFXW	12SFXTW	0.75	2.38	2.81	0.937	2.000	1.12	0.75	1.656	1.280	0.325	0.406	3/8-16
16SFXW	16SFXTW	1.00	2.75	3.19	1.093	2.250	1.31	0.94	1.906	1.530	0.355	0.469	7/16-14
20SFXW	20SFXTW	1.25	3.06	3.75	1.250	2.625	1.50	1.06	2.156	1.750	0.385	0.531	1/2-13
24SFXW	24SFXTW	1.50	3.75	4.44	1.437	3.125	1.69	1.19	2.531	2.030	0.475	0.656	5/8-11
32SFXW	32SFXTW	2.00	4.50	5.25	1.750	3.812	2.06	1.44	3.156	2.660	0.475	0.781	3/4-10

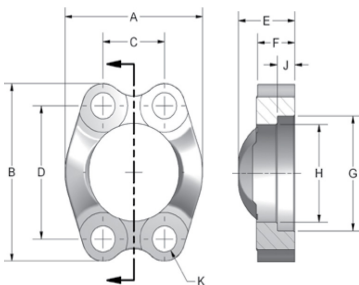
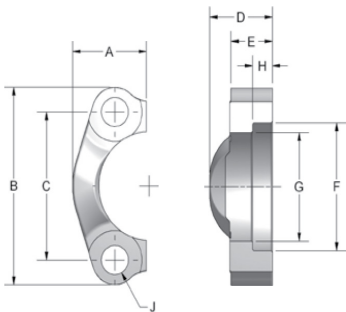

SPLIT FLANGE ADAPTERS

FLANGES -
CARBON STEEL

JIC THREAD

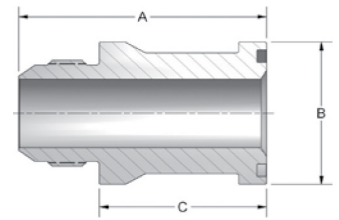

CODE 61 JIC THREAD

PART NO.	TUBE O.D.	FLANGE SIZE	A	B	C	THREAD
300-8-8	1/2	1/2	2.60	1.188	1.94	3/4-16
300-8-12	1/2	3/4	2.75	1.500	2.09	3/4-16
300-12-12	3/4	3/4	2.75	1.500	1.89	1 1/16-12
300-16-12	1	3/4	2.75	1.500	1.84	1 5/16-12
300-12-16	3/4	1	2.80	1.750	1.94	1 1/16-12
300-16-16	1	1	2.80	1.750	1.89	1 5/16-12
300-20-16	1 1/4	1	2.80	1.750	1.84	1 5/8-12
300-12-20	3/4	1 1/4	2.80	2.000	1.94	1 1/16-12
300-16-20	1	1 1/4	2.80	2.000	1.89	1 5/16-12
300-20-20	1 1/4	1 1/4	2.80	2.000	1.84	1 5/8-12
300-24-20	1 1/2	1 1/4	3.40	2.000	2.32	1 7/8-12
300-16-24	1	1 1/2	3.33	2.380	2.42	1 5/16-12
300-20-24	1 1/4	1 1/2	3.38	2.375	2.42	1 5/8-12
300-24-24	1 1/2	1 1/2	3.50	2.375	2.42	1 7/8-12
300-32-24	2	1 1/2	4.20	2.375	2.87	2 1/2-12
300-20-32	1 1/4	2	3.60	2.810	2.64	1 5/8-12
300-24-32	1 1/2	2	3.73	2.812	2.64	1 7/8-12
300-32-32	2	2	3.98	2.812	2.64	2 1/2-12
300-32-40	2	2 1/2	3.98	3.312	2.64	2 1/2-12

CODE 62 JIC THREAD

PART NO.	TUBE O.D.	FLANGE SIZE	A	B	C	THREAD
600-8-8	1/2	1/2	2.61	1.250	1.95	3/4-16
600-12-12	3/4	3/4	2.75	1.625	1.89	1 1/16-12
600-16-12	1	3/4	2.75	1.625	1.84	1 5/16-12
600-20-12	1 1/4	3/4	3.05	1.625	2.09	1 5/8-12
600-12-16	3/4	1	2.80	1.875	1.94	1 1/16-12
600-16-16	1	1	2.80	1.875	1.89	1 5/16-12
600-20-16	1 1/4	1	2.80	1.875	1.84	1 5/8-12
600-16-20	1	1 1/4	3.05	2.125	2.14	1 5/16-12
600-20-20	1 1/4	1 1/4	3.05	2.125	2.09	1 5/8-12
600-24-20	1 1/2	1 1/4	3.30	2.125	2.22	1 7/8-12
600-16-24	1	1 1/2	3.33	2.500	2.42	1 5/16-12
600-20-24	1 1/4	1 1/2	3.50	2.500	2.54	1 5/8-12
600-24-24	1 1/2	1 1/2	3.50	2.500	2.42	1 7/8-12
600-32-24	2	1 1/2	4.94	2.500	3.61	2 1/2-12
600-24-32	1 1/2	2	3.98	3.125	2.89	1 7/8-12
600-32-32	2	2	4.23	3.125	2.89	2 1/2-12

SAE STRAIGHT THREAD

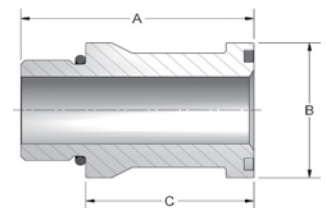

CODE 61 SAE STRAIGHT THREAD

PART NO.	TUBE O.D.	FLANGE SIZE	A	B	C	THREAD
302-8-8	1/2	1/2	2.49	1.188	1.94	3/4-16
302-12-12	3/4	3/4	2.61	1.500	1.89	1 1/16-12
302-16-12	1	3/4	2.88	1.500	2.16	1 5/16-12
302-12-16	3/4	1	2.74	1.750	2.02	1 1/16-12
302-16-16	1	1	2.61	1.750	1.89	1 5/16-12
302-20-16	1 1/4	1	3.13	1.750	2.41	1 5/8-12
302-16-20	1	1 1/4	2.74	2.000	2.02	1 5/16-12
302-20-20	1 1/4	1 1/4	3.13	2.000	2.41	1 5/8-12
302-24-20	1 1/2	1 1/4	3.43	2.000	2.71	1 7/8-12
302-16-24	1	1 1/2	3.30	2.380	2.58	1 5/16-12
302-20-24	1 1/4	1 1/2	3.30	2.375	2.58	1 5/8-12
302-24-24	1 1/2	1 1/2	3.14	2.375	2.42	1 7/8-12
302-24-32	1 1/2	2	3.79	2.812	3.07	1 7/8-12
302-32-32	2	2	3.63	2.812	2.91	2 1/2-12
302-40-40	2 1/2	2 1/2	4.23	3.310	3.08	3-12
302-48-48	3	3	4.50	4.000	3.36	3 1/2-12
302-64-64	4	4	4.14	5.000	2.89	4 1/2-12

CODE 62 SAE STRAIGHT THREAD

PART NO.	TUBE O.D.	FLANGE SIZE	A	B	C	THREAD
602-8-8	1/2	1/2	2.50	1.250	1.95	3/4-16
602-12-12	3/4	3/4	2.62	1.625	1.89	1 1/16-12
602-16-12	1	3/4	2.88	1.625	2.15	1 5/16-12
602-12-16	3/4	1	2.75	1.875	2.02	1 1/16-12
602-16-16	1	1	2.62	1.875	1.89	1 5/16-12
602-20-16	1 1/4	1	3.44	1.875	2.71	1 5/8-12
602-16-20	1	1 1/4	3.12	2.125	2.39	1 5/16-12
602-20-20	1 1/4	1 1/4	3.00	2.125	2.27	1 5/8-12
602-24-20	1 1/2	1 1/4	3.44	2.125	2.71	1 7/8-12
602-20-24	1 1/4	1 1/2	3.31	2.500	2.58	1 5/8-12
602-24-24	1 1/2	1 1/2	3.19	2.500	2.46	1 7/8-12
602-24-32	1 1/2	2	3.90	3.125	3.17	1 7/8-12
602-32-32	2	2	3.75	3.125	3.02	2 1/2-12

ORFS THREAD

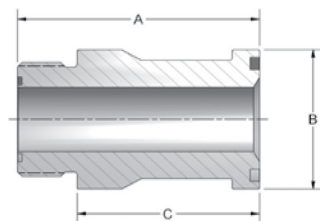

CODE 61 ORFS THREAD

PART NO.	TUBE O.D.	FLANGE SIZE	A	B	C	THREAD
304-12-12	3/4	3/4	2.75	1.500	2.08	1 3/16-12
304-16-12	1	3/4	2.75	1.500	2.06	1 7/16-12
304-12-16	3/4	1	2.80	1.750	2.13	1 3/16-12
304-16-16	1	1	2.80	1.750	2.11	1 7/16-12
304-20-16	1 1/4	1	2.80	1.750	2.11	1 11/16-12
304-16-20	1	1-1/4	2.80	2.000	2.11	1 7/16-12
304-20-20	1 1/4	1-1/4	2.80	2.000	2.11	1 11/16-12
304-24-20	1 1/2	1-1/4	3.20	2.000	2.51	2-12
304-20-24	1 1/4	1-1/2	3.50	2.375	2.81	1 11/16-12
304-24-24	1 1/2	1-1/2	3.50	2.375	2.81	2-12
304-24-32	1 1/2	2	3.33	2.812	2.64	2-12

CODE 62 ORFS THREAD

PART NO.	TUBE O.D.	FLANGE SIZE	A	B	C	THREAD
604-8-8	1/2	1/2	2.58	1.250	2.08	13/16-16
604-12-12	3/4	3/4	2.75	1.625	2.08	1 3/16-12
604-16-12	1	3/4	2.75	1.625	2.06	1 7/16-12
604-12-16	3/4	1	2.80	1.875	2.13	1 3/16-12
604-16-16	1	1	2.80	1.875	2.11	1 7/16-12
604-20-16	1 1/4	1	3.20	1.875	2.51	1 11/16-12
604-16-20	1	1 1/4	3.05	2.125	2.36	1 7/16-12
604-20-20	1 1/4	1 1/4	3.05	2.125	2.36	1 11/16-12
604-24-20	1 1/2	1 1/4	3.30	2.125	2.61	2-12
604-20-24	1 1/4	1 1/2	3.50	2.500	2.81	1 11/16-12
604-24-24	1 1/2	1 1/2	3.50	2.500	2.81	2-12
604-24-32	1 1/2	2	3.58	3.125	2.89	2-12

45° JIC THREAD

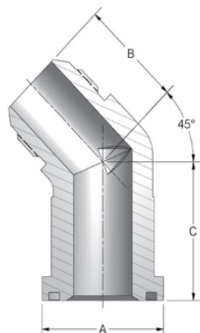

CODE 61 45° JIC THREAD

PART NO.	TUBE O.D.	FLANGE SIZE	A	B	C	THREAD
340-12-12	3/4	3/4	1.500	1.28	1.58	1 1/16-12
340-16-16	1	1	1.750	1.47	1.85	1 5/16-12
340-20-20	1 1/4	1 1/4	2.000	1.59	2.04	1 5/8-12
340-24-24	1 1/2	1 1/2	2.375	1.78	2.38	1 7/8-12
340-32-32	2	2	2.812	2.22	3.00	2 1/2-12

CODE 62 45° JIC THREAD

PART NO.	TUBE O.D.	FLANGE SIZE	A	B	C	THREAD
640-12-12	3/4	3/4	1.625	1.28	1.58	1 1/16-12
640-16-16	1	1	1.875	1.47	1.85	1 5/16-12
640-20-20	1 1/4	1 1/4	2.125	1.59	2.04	1 5/8-12
640-24-24	1 1/2	1 1/2	2.500	1.78	2.38	1 7/8-12
640-32-32	2	2	3.13	2.22	3.00	2 1/2-12

45° ORFS THREAD

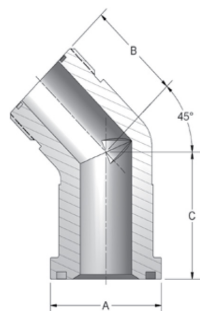

CODE 61 45° ORFS THREAD

PART NO.	TUBE O.D.	FLANGE SIZE	A	B	C	THREAD
344-12-12	3/4	3/4	1.500	1.28	1.58	1 3/16-12
344-16-16	1	1	1.750	1.47	1.85	1 7/16-12
344-20-20	1 1/4	1 1/4	2.000	1.59	2.04	1 11/16-12
344-24-24	1 1/2	1 1/2	2.375	1.78	2.38	2-12

CODE 62 45° ORFS THREAD

PART NO.	TUBE O.D.	FLANGE SIZE	A	B	C	THREAD
644-12-12	3/4	3/4	1.625	1.28	1.58	1 3/16-12
644-16-16	1	1	1.875	1.47	1.85	1 7/16-12
644-20-20	1 1/4	1 1/4	2.125	1.59	2.04	1 11/16-12
644-24-24	1 1/2	1 1/2	2.500	1.78	2.38	2-12

SPLIT FLANGE ADAPTERS

FLANGES -
CARBON STEEL

90° JIC THREAD

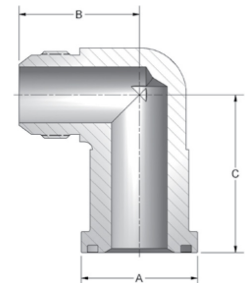

CODE 61 90° JIC THREAD

PART NO.	TUBE O.D.	FLANGE SIZE	A	B	C	THREAD
390-8-8	1/2	1/2	1.19	1.46	2.13	3/4-16
390-8-12	1/2	3/4	1.500	1.66	2.13	3/4-16
390-12-12	3/4	3/4	1.500	1.66	2.13	1 1/16-12
390-16-12	1	3/4	1.500	1.66	2.13	1 5/16-12
390-12-16	3/4	1	1.750	1.81	2.37	1 1/16-12
390-16-16	1	1	1.750	1.81	2.37	1 5/16-12
390-20-16	1 1/4	1	1.750	1.81	2.37	1 5/8-12
390-12-20	3/4	1 1/4	2.000	2.06	2.62	1 1/16-12
390-16-20	1	1 1/4	2.000	2.06	2.62	1 5/16-12
390-20-20	1 1/4	1 1/4	2.000	2.06	2.62	1 5/8-12
390-24-20	1 1/2	1 1/4	2.000	2.06	2.62	1 7/8-12
390-12-24	3/4	1 1/2	2.375	2.33	3.15	1 1/16-12
390-16-24	1	1 1/2	2.375	2.33	3.15	1 5/16-12
390-20-24	1 1/4	1 1/2	2.375	2.33	3.15	1 5/8-12
390-24-24	1 1/2	1 1/2	2.375	2.33	3.15	1 7/8-12
390-32-24	2	1 1/2	2.375	2.58	3.15	2 1/2-12
390-24-32	1 1/2	2	2.812	3.06	4.25	1 7/8-12
390-32-32	2	2	2.812	3.06	4.25	2 1/2-12
390-32-40	2	2 1/2	3.312	3.06	4.25	2 1/2-12

CODE 62 90° JIC THREAD

PART NO.	TUBE O.D.	FLANGE SIZE	A	B	C	THREAD
690-8-8	1/2	1/2	1.250	1.46	2.13	3/4-16
690-12-12	3/4	3/4	1.625	1.66	2.13	1-1/16-12
690-16-12	1	3/4	1.625	1.66	2.13	1-5/16-12
690-12-16	3/4	1	1.875	1.81	2.37	1-1/16-12
690-16-16	1	1	1.875	1.81	2.37	1-5/16-12
690-20-16	1-1/4	1	1.875	1.81	2.37	1-5/8-12
690-16-20	1	1-1/4	2.125	2.06	2.76	1-5/16-12
690-20-20	1-1/4	1-1/4	2.125	2.06	2.76	1-5/8-12
690-24-20	1-1/2	1-1/4	2.125	2.19	2.76	1-7/8-12
690-20-24	1-1/4	1-1/2	2.500	2.33	3.15	1-5/8-12
690-24-24	1-1/2	1-1/2	2.500	2.33	3.15	1-7/8-12
690-32-24	2	1-1/2	2.500	3.06	4.25	2-1/2-12
690-24-32	1-1/2	2	3.125	3.06	4.25	1-7/8-12
690-32-32	2	2	3.125	3.06	4.25	2-1/2-12

90° ORFS THREAD

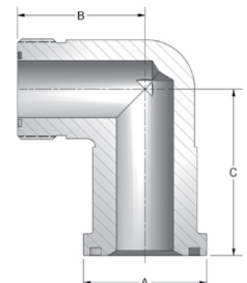

CODE 61 90° ORFS THREAD

PART NO.	TUBE O.D.	FLANGE SIZE	A	B	C	THREAD
394-12-12	3/4	3/4	1.500	1.66	2.13	1 3/16-12
394-16-12	1	3/4	1.500	1.66	2.13	1 7/16-12
394-12-16	3/4	1	1.750	1.81	2.37	1 3/16-12
394-16-16	1	1	1.750	1.81	2.37	1 7/16-12
394-20-16	1 1/4	1	1.750	1.81	2.37	1 11/16-12
394-16-20	1	1 1/4	2.000	2.06	2.62	1 7/16-12
394-20-20	1 1/4	1 1/4	2.000	2.06	2.62	1 11/16-12
394-24-20	1 1/2	1 1/4	2.000	2.06	2.62	2-12
394-20-24	1 1/4	1 1/2	2.375	2.33	3.15	1 11/16-12
394-24-24	1 1/2	1 1/2	2.375	2.33	3.15	2-12
394-24-32	1 1/2	2	2.812	3.06	4.25	2-12

CODE 62 90° ORFS THREAD

PART NO.	TUBE O.D.	FLANGE SIZE	A	B	C	THREAD
694-12-8	3/4	1/2	1.250	1.66	2.13	1-3/16-12
694-12-12	3/4	3/4	1.625	1.66	2.13	1-3/16-12
694-16-12	1	3/4	1.625	1.66	2.13	1-7/16-12
694-12-16	3/4	1	1.875	1.81	2.37	1-3/16-12
694-16-16	1	1	1.875	1.81	2.37	1-7/16-12
694-20-16	1-1/4	1	1.875	1.81	2.37	1-11/16-12
694-16-20	1	1-1/4	2.125	2.06	2.76	1-7/16-12
694-20-20	1-1/4	1-1/4	2.125	2.06	2.76	1-11/16-12
694-24-20	1-1/2	1-1/4	2.125	2.06	2.76	2-12
694-20-24	1-1/4	1-1/2	2.500	2.33	3.15	1-11/16-12
694-24-24	1-1/2	1-1/2	2.500	2.33	3.15	2-12
694-24-32	1-1/2	2	3.125	3.06	4.25	2-12

FLANGE HEAD X FLANGE HEAD

FLANGES -
CARBON STEEL

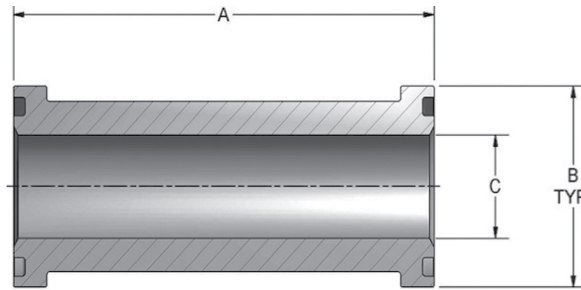
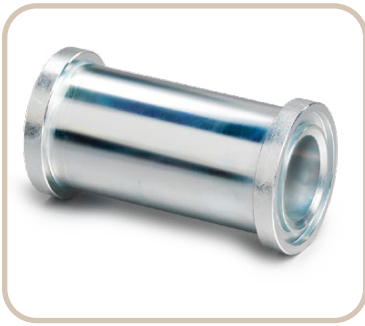

- Used to connect two flat faced flanges
- One-piece forged carbon steel construction with Silver Trivalent plating

CODE 61 FLANGE HEAD X FLANGE HEAD

PART NO.	FLANGE SIZE	A	B	C
301-8-8	0.50	4.00	1.188	0.406
301-12-12	0.75	4.00	1.500	0.656
301-16-16	1.00	4.00	1.750	0.906
301-20-20	1.25	4.00	2.000	1.125
301-24-24	1.50	4.00	2.375	1.375
301-32-32	2.00	4.00	2.812	1.875
301-40-40	2.50	6.00	3.312	2.375
301-48-48	3.00	6.00	4.000	2.875
301-56-56	3.50	6.00	4.500	3.375
301-64-64	4.00	6.00	5.000	3.875

CODE 62 FLANGE HEAD X FLANGE HEAD

PART NO.	FLANGE SIZE	A	B	C
601-8-8	0.50	4.00	1.250	0.406
601-12-12	0.75	4.00	1.625	0.656
601-16-16	1.00	6.00	1.875	0.810
601-20-20	1.25	6.00	2.125	1.010
601-24-24	1.50	6.00	2.500	1.250
601-32-32	2.00	8.00	3.125	1.750

Stainless steel and custom lengths available upon request

BUTT WELD FLANGE HEAD

FLANGES -
CARBON STEEL

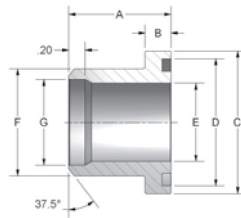

FIGURE 1

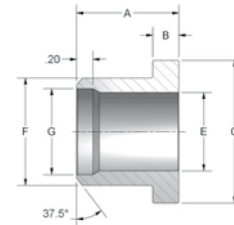

FIGURE 2

CODE 61 BUTT WELD TO FLANGE HEAD FOR SCHEDULE 40 PIPE

PART NO. O-RING FIG. 1	PART NO. FLAT FACE FIG. 2	PIPE SIZE	CLAMP SIZE	A	B	C	D	E	F	G
8P-8BWSF-40	8P-8BWSFN-40	0.50	0.50	1.06	0.265	1.188	1.000	0.548	0.840	0.624
12P-12BWSF-40	12P-12BWSFN-40	0.75	0.75	1.06	0.265	1.500	1.250	0.744	1.050	0.826
16P-16BWSF-40	16P-16BWSFN-40	1.00	1.00	1.25	0.315	1.750	1.560	0.959	1.315	1.051
20P-20BWSF-40	20P-20BWSFN-40	1.25	1.25	1.44	0.315	2.000	1.750	1.280	1.660	1.382
24P-24BWSF-40	24P-24BWSFN-40	1.50	1.50	1.75	0.315	2.375	2.115	1.502	1.900	1.612
32P-32BWSF-40	32P-32BWSFN-40	2.00	2.00	2.00	0.375	2.812	2.490	1.941	2.375	2.069
40P-40BWSF-40	40P-40BWSFN-40	2.50	2.50	2.31	0.375	3.312	2.995	2.325	2.875	2.471
48P-48BWSF-40	48P-48BWSFN-40	3.00	3.00	2.31	0.375	4.000	3.615	2.902	3.500	3.070
64P-64BWSF-40	64P-64BWSFN-40	4.00	4.00	1.90	0.442	5.000	4.595	3.828	4.500	4.028



CODE 61 BUTT WELD TO FLANGE HEAD FOR SCHEDULE 80 PIPE

PART NO. O-RING FIG. 1	PART NO. FLAT FACE FIG. 2	PIPE SIZE	CLAMP SIZE	A	B	C	D	E	F
8P-8BWSF-80	8P-8BWSFN-80	0.50	0.50	1.06	0.265	1.188	1.000	0.548	0.840
12P-12BWSF-80	12P-12BWSFN-80	0.75	0.75	1.06	0.265	1.500	1.250	0.744	1.050
16P-16BWSF-80	16P-16BWSFN-80	1.00	1.00	1.25	0.315	1.750	1.560	0.959	1.315
20P-20BWSF-80	20P-20BWSFN-80	1.25	1.25	1.44	0.315	2.000	1.750	1.280	1.660
24P-24BWSF-80	24P-24BWSFN-80	1.50	1.50	1.75	0.315	2.375	2.115	1.502	1.900
32P-32BWSF-80	32P-32BWSFN-80	2.00	2.00	2.00	0.375	2.812	2.490	1.941	2.375
40P-40BWSF-80	40P-40BWSFN-80	2.50	2.50	2.31	0.375	3.312	2.995	2.325	2.875
48P-48BWSF-80	48P-48BWSFN-80	3.00	3.00	2.31	0.375	4.000	3.615	2.902	3.500

CODE 61 BUTT WELD TO FLANGE HEAD FOR SCHEDULE 160 PIPE

PART NO. O-RING FIG. 1	PART NO. FLAT FACE FIG. 2	PIPE SIZE	CLAMP SIZE	A	B	C	D	E	F
8P-8BWSF-160	8P-8BWSFN-160	0.50	0.50	1.06	0.265	1.188	1.000	0.464	0.840
12P-12BWSF-160	12P-12BWSFN-160	0.75	0.75	1.06	0.265	1.500	1.250	0.612	1.050
16P-16BWSF-160	16P-16BWSFN-160	1.00	1.00	1.25	0.315	1.750	1.560	0.815	1.315
20P-20BWSF-160	20P-20BWSFN-160	1.25	1.25	1.44	0.315	2.000	1.750	1.160	1.660
24P-24BWSF-160	24P-24BWSFN-160	1.50	1.50	1.75	0.315	2.375	2.115	1.338	1.900
32P-32BWSF-160	32P-32BWSFN-160	2.00	2.00	2.00	0.375	2.812	2.490	1.687	2.375
40P-40BWSF-160	40P-40BWSFN-160	2.50	2.50	2.31	0.375	3.312	2.995	2.125	2.875
48P-40BWSF-160	48P-40BWSFN-160	3.00	3.00	2.31	0.375	4.000	3.615	2.624	3.500

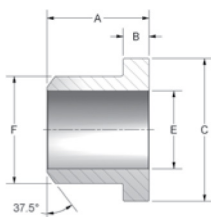

FIGURE 1

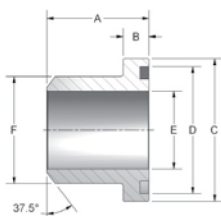

FIGURE 2

BUTT WELD FLANGE HEAD

FLANGES -
CARBON STEEL

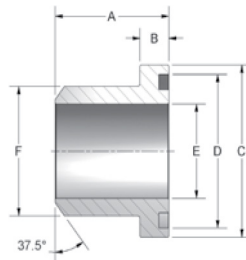

FIGURE 1

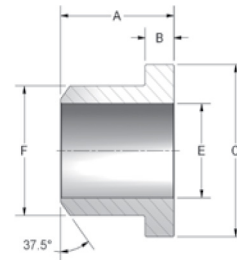

FIGURE 2

CODE 62 BUTT WELD TO FLANGE HEAD FOR SCHEDULE 80 PIPE

PART NO. O-RING FIG. 1	PART NO. FLAT FACE FIG. 2	PIPE SIZE	CLAMP SIZE	A	B	C	D	E	F
8P-8BWSFX-80	8P-8BWSFXN-80	0.50	0.50	1.10	0.305	1.250	1.000	0.548	0.840
12P-12BWSFX-80	12P-12BWSFXN-80	0.75	0.75	1.42	0.345	1.625	1.250	0.744	1.050
16P-16BWSFX-80	16P-16BWSFXN-80	1.00	1.00	1.61	0.375	1.875	1.560	0.959	1.315
20P-20BWSFX-80	20P-20BWSFXN-80	1.25	1.25	1.73	0.405	2.125	1.750	1.280	1.660
24P-24BWSFX-80	24P-24BWSFXN-80	1.50	1.50	2.17	0.495	2.500	2.115	1.502	1.900
32P-32BWSFX-80	32P-32BWSFXN-80	2.00	2.00	2.48	0.495	3.125	2.490	1.941	2.375

CODE 62 BUTT WELD TO FLANGE HEAD FOR SCHEDULE 160 PIPE

PART NO. O-RING FIG. 1	PART NO. FLAT FACE FIG. 2	PIPE SIZE	CLAMP SIZE	A	B	C	D	E	F
8P-8BWSFX-160	8P-8BWSFXN-160	0.50	0.50	1.10	0.305	1.250	1.000	0.464	0.840
12P-12BWSFX-160	12P-12BWSFXN-160	0.75	0.75	1.42	0.345	1.625	1.250	0.612	1.050
16P-16BWSFX-160	16P-16BWSFXN-160	1.00	1.00	1.61	0.375	1.875	1.560	0.815	1.315
20P-20BWSFX-160	20P-20BWSFXN-160	1.25	1.25	1.73	0.405	2.125	1.750	1.160	1.660
24P-24BWSFX-160	24P-24BWSFXN-160	1.50	1.50	2.17	0.495	2.500	2.115	1.338	1.900
32P-32BWSFX-160	32P-32BWSFXN-160	2.00	2.00	2.48	0.495	3.125	2.490	1.687	2.375

CODE 62 BUTT WELD TO FLANGE HEAD FOR SCHEDULE XXS PIPE

PART NO. O-RING FIG. 1	PART NO. FLAT FACE FIG. 2	PIPE SIZE	CLAMP SIZE	A	B	C	D	E	F
8P-8BWSFX-XXS	8P-8BWSFXN-XXS	0.50	0.50	1.10	0.305	1.250	1.000	0.252	0.840
12P-12BWSFX-XXS	12P-12BWSFXN-XXS	0.75	0.75	1.42	0.345	1.625	1.250	0.434	1.050
16P-16BWSFX-XXS	16P-16BWSFXN-XXS	1.00	1.00	1.61	0.375	1.875	1.560	0.599	1.315
20P-20BWSFX-XXS	20P-20BWSFXN-XXS	1.25	1.25	1.73	0.405	2.125	1.750	0.896	1.660
24P-24BWSFX-XXS	24P-24BWSFXN-XXS	1.50	1.50	2.17	0.495	2.500	2.115	1.100	1.900
32P-32BWSFX-XXS	32P-32BWSFXN-XXS	2.00	2.00	2.48	0.495	3.125	2.490	1.503	2.375

FEMALE FLANGE HEAD ADAPTER

FLANGES -
CARBON STEEL



CODE 61 SOCKET WELD TO FLANGE HEAD FOR PIPE

PART NO.	PIPE SIZE	CLAMP SIZE	A	B	C	D	E	F	G	H	J
8P-8WSF	0.50	0.50	2.34	0.56	0.265	1.187	1.000	0.500	1.25	0.855	0.924
12P-12WSF	0.75	0.75	2.34	0.56	0.265	1.500	1.250	0.750	1.50	1.062	1.234
16P-16WSF	1.00	1.00	2.38	0.63	0.315	1.750	1.560	1.000	1.75	1.328	1.484
20P-20WSF	1.25	1.25	2.62	0.68	0.315	2.000	1.750	1.250	2.00	1.672	1.684
24P-24WSF	1.50	1.50	2.88	0.76	0.315	2.375	2.115	1.500	2.38	1.922	1.964
32P-32WSF	2.00	2.00	3.00	0.88	0.375	2.812	2.490	2.000	2.81	2.406	2.434
40P-40WSF	2.50	2.50	3.06	1.00	0.375	3.312	2.995	2.500	3.31	2.906	2.920
48P-48WSF	3.00	3.00	3.88	1.25	0.375	4.000	3.615	2.875	4.00	3.547	3.534

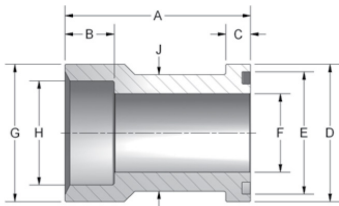

CODE 62 SOCKET WELD TO FLANGE HEAD FOR PIPE

PART NO.	PIPE SIZE	CLAMP SIZE	A	B	C	D	E	F	G	H	J
W53-12-12	0.75	0.75	2.75	0.630	0.345	1.625	1.250	0.750	1.750	1.062	1.234
W53-16-16	1.00	1.00	3.06	0.630	0.375	1.875	1.560	1.000	2.000	1.328	1.484
W53-20-20	1.25	1.25	3.31	0.690	0.405	2.125	1.750	1.125	2.312	1.672	1.704
W53-24-24	1.50	1.50	3.93	0.750	0.495	2.500	2.115	1.375	2.750	1.922	1.984
W53-32-32	2.00	2.00	4.06	0.880	0.495	3.125	2.490	1.875	3.125	2.406	2.604



CODE 61 NPTF THREAD TO FLANGE HEAD

PART NO.	PIPE SIZE	CLAMP SIZE	A	B	C	D	E	F	G	H
12F-12FO	0.75	0.75	2.47	0.265	1.500	1.250	0.75	1.50	0.75	1.234
16F-16FO	1.00	1.00	2.66	0.315	1.750	1.560	1.00	1.75	1.00	1.484
20F-20FO	1.25	1.25	2.84	0.315	2.000	1.750	1.25	2.00	1.25	1.684
24F-24FO	1.50	1.50	3.00	0.315	2.375	2.115	1.50	2.38	1.50	1.964
32F-32FO	2.00	2.00	3.00	0.375	2.812	2.490	2.00	2.81	2.00	2.434

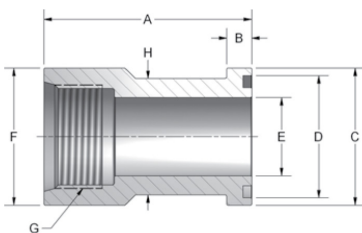

CODE 61 SAE THREAD TO FLANGE HEAD

PART NO.	PIPE SIZE	CLAMP SIZE	A	B	C	D	E	F	G	H
12S-12FO	0.75	0.75	2.47	0.265	1.500	1.250	0.75	1.50	1 1/16-12	1.234
16S-16FO	1.00	1.00	2.66	0.315	1.750	1.560	1.00	1.75	1 5/16-12	1.484
20S-20FO	1.25	1.25	2.84	0.315	2.000	1.750	1.25	2.00	1 5/8-12	1.684
24S-24FO	1.50	1.50	3.00	0.315	2.375	2.115	1.50	2.38	1 7/8-12	1.964
32S-32FO	2.00	2.00	3.00	0.375	2.812	2.490	2.00	2.81	2 1/2-12	2.434

TUBE FLANGE HEAD FITTING

**FLANGES -
CARBON STEEL**

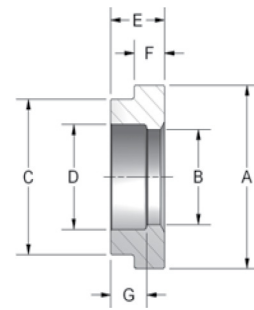
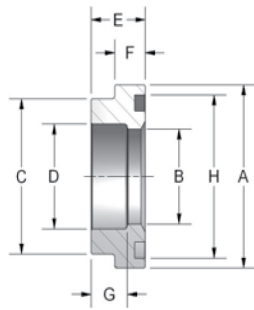

CODE 61 TUBE FLANGE HEAD FITTING

PART NO. O-RING FIG. 1	PART NO. FLAT FACE FIG. 2	TUBE SIZE	FLANGE SIZE	A	B	C	D	E	F	G	H
8T-8SF	8T-8SFN	0.50	0.50	1.188	0.406	0.924	0.502	0.50	0.265	0.312	1.000
10T-8SF	10T-8SFN	0.63	0.50	1.188	0.500	0.924	0.627	0.50	0.265	0.312	1.000
12T-12SF	12T-12SFN	0.75	0.75	1.500	0.656	1.234	0.752	0.56	0.265	0.375	1.250
16T-12SF	16T-12SFN	1.00	0.75	1.500	0.750	1.234	1.002	0.56	0.265	0.375	1.250
16T-16SF	16T-16SFN	1.00	1.00	1.750	0.906	1.484	1.002	0.56	0.315	0.375	1.560
20T-16SF	20T-16SFN	1.25	1.00	1.750	1.000	1.484	1.252	0.56	0.315	0.375	1.560
20T-20SF	20T-20SFN	1.25	1.25	2.000	1.125	1.684	1.252	0.56	0.315	0.375	1.750
24T-20SF	24T-20SFN	1.50	1.25	2.000	1.250	1.684	1.502	0.56	0.315	0.375	1.750
24T-24SF	24T-24SFN	1.50	1.50	2.375	1.375	1.964	1.502	0.62	0.315	0.438	2.115
28T-24SF	28T-24SFN	1.75	1.50	2.375	1.500	1.964	1.752	0.62	0.315	0.438	2.115
32T-32SF	32T-32SFN	2.00	2.00	2.812	1.875	2.434	2.002	0.62	0.375	0.500	2.490
36T-32SF	36T-32SFN	2.25	2.00	2.812	2.000	2.434	2.252	0.62	0.375	0.437	2.490
40T-40SF	40T-40SFN	2.50	2.50	3.312	2.375	2.904	2.502	0.68	0.375	0.562	2.995
44T-40SF	44T-40SFN	2.75	2.50	3.312	2.500	2.904	2.752	0.68	0.375	0.500	2.995
48T-48SF	48T-48SFN	3.00	3.00	4.000	2.875	3.534	3.002	0.75	0.375	0.562	3.615
56T-56SF	56T-56SFN	3.50	3.50	4.500	3.380	3.980	3.502	0.88	0.440	0.750	4.100
64T-64SF	64T-64SFN	4.00	4.00	5.000	3.880	4.480	4.040	1.00	0.440	0.810	4.600
80T-80SF	80T-80SFN	5.00	5.00	6.000	4.880	5.480	5.002	1.13	0.440	0.940	5.600

CODE 62 TUBE FLANGE HEAD FITTING

PART NO. O-RING FIG. 1	PART NO. FLAT FACE FIG. 2	TUBE SIZE	FLANGE SIZE	A	B	C	D	E	F	G	H
12T-12SFX	12T-12SFXN	0.75	0.75	1.625	0.656	1.234	0.752	0.69	0.345	0.500	1.250
16T-12SFX	16T-12SFXN	1.00	0.75	1.625	0.750	1.234	1.002	0.69	0.345	0.500	1.250
16T-16SFX	16T-16SFXN	1.00	1.00	1.875	0.810	1.484	1.002	0.81	0.375	0.625	1.560
20T-16SFX	20T-16SFXN	1.25	1.00	1.875	1.000	1.484	1.252	0.81	0.375	0.625	1.560
20T-20SFX	20T-20SFXN	1.25	1.25	2.125	1.010	1.704	1.252	1.00	0.405	0.812	1.750
24T-20SFX	24T-20SFXN	1.50	1.25	2.125	1.250	1.704	1.502	1.00	0.405	0.812	1.750
24T-24SFX	24T-24SFXN	1.50	1.50	2.500	1.250	1.984	1.502	1.19	0.495	1.000	2.115
28T-24SFX	28T-24SFXN	1.75	1.50	2.500	1.500	1.984	1.757	1.19	0.495	1.000	2.115
32T-32SFX	32T-32SFXN	2.00	2.00	3.125	1.750	2.604	2.002	1.50	0.495	1.375	2.490
36T-32SFX	36T-32SFXN	2.25	2.00	3.125	2.000	2.604	2.252	1.50	0.495	1.312	2.490

For sizes not listed, please contact Trilex.

CONNECTOR BLOCK & PLATE

FLANGES -
CARBON STEEL

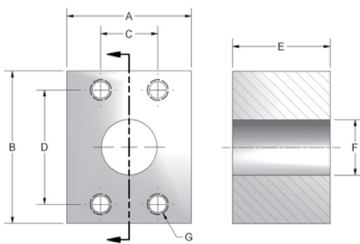

CODE 61 CONNECTOR BLOCK

PART NO.	PAD SIZE	A	B	C	D	E	F	G UNC-2B
ACB 8-8	0.50	2.00	2.12	0.688	1.500	1.75	0.502	5/16-18
ACB 12-12	0.75	2.00	2.62	0.875	1.875	1.75	0.752	3/8-16
ACB 16-16	1.00	2.25	2.75	1.031	2.062	1.75	1.002	3/8-16
ACB 20-20	1.25	3.00	3.19	1.188	2.312	2.125	1.252	7/16-14
ACB 24-24	1.50	3.50	3.75	1.406	2.750	2.125	1.502	1/2-13
ACB 32-32	2.00	3.88	4.00	1.688	3.062	2.125	1.942	1/2-13
ACB 40-40	2.50	4.38	4.50	2.000	3.500	2.375	2.442	1/2-13

CODE 62 CONNECTOR BLOCK

PART NO.	PAD SIZE	A	B	C	D	E	F	G UNC-2B
ACBX 8-8	0.50	2.00	2.22	0.718	1.594	1.75	0.502	5/16-18
ACBX 12-12	0.75	2.50	2.81	0.937	2.000	2.00	0.752	3/8-16
ACBX 16-16	1.00	2.75	3.19	1.093	2.250	2.00	1.002	7/16-14
ACBX 20-20	1.25	3.00	3.75	1.250	2.625	2.00	1.252	1/2-13
ACBX 24-24	1.50	3.88	4.50	1.437	3.125	2.50	1.502	5/8-11
ACBX 32-32	2.00	4.50	5.25	1.750	3.812	2.95	1.942	3/4-10

- Used to connect two O-ring Flanges

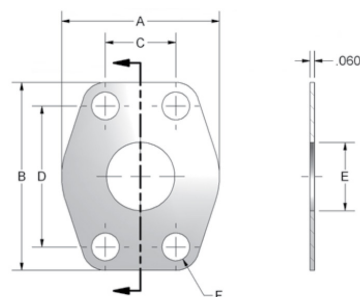

CODE 61 CONNECTOR PLATE

PART NO.	PAD SIZE	A	B	C	D	E	F
8 CP	0.50	1.81	2.12	0.688	1.500	0.50	0.344
12 CP	0.75	2.06	2.56	0.875	1.875	0.75	0.406
16 CP	1.00	2.31	2.75	1.031	2.062	1.00	0.406
20 CP	1.25	2.88	3.12	1.188	2.312	1.25	0.469
24 CP	1.50	3.25	3.69	1.406	2.750	1.50	0.531
32 CP	2.00	3.81	4.00	1.688	3.062	2.00	0.531
40 CP	2.50	4.12	4.44	2.000	3.500	2.50	0.531
48 CP	3.00	5.16	5.31	2.438	4.188	3.00	0.656

CODE 62 CONNECTOR PLATE

PART NO.	PAD SIZE	A	B	C	D	E	F
12 CPX	0.75	2.38	2.81	0.937	2.000	0.750	0.406
16 CPX	1.00	2.75	3.19	1.093	2.250	1.000	0.469
20 CPX	1.25	3.06	3.75	1.250	2.625	1.250	0.531
24 CPX	1.50	3.75	4.44	1.437	3.125	1.500	0.656
32 CPX	2.00	4.50	5.25	1.750	3.812	2.000	0.781

GAUGE PORT SPACER

FLANGES -
CARBON STEEL

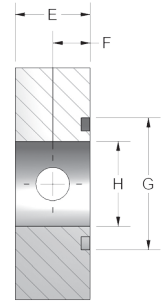
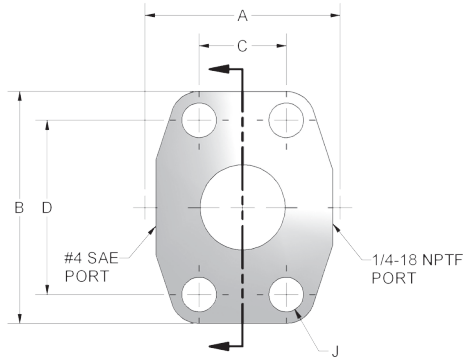
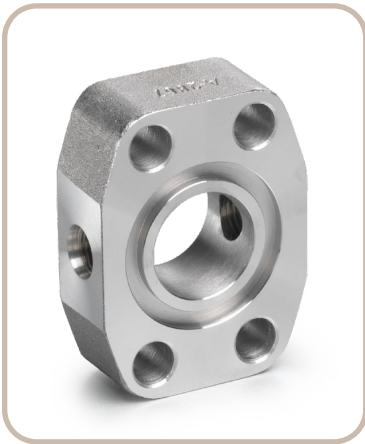

- Includes O-ring and plugs for both ports

CODE 61 GAUGE PORT O-RING SPACER

PART NO.	PAD SIZE	A	B	C	D	E	F	G	H	J
AS-8-GP	0.50	1.82	2.16	0.688	1.500	1.25	0.620	1.000	0.502	0.344
AS-12-GP	0.75	2.06	2.69	0.875	1.875	1.25	0.620	1.250	0.752	0.406
AS-16-GP	1.00	2.31	2.75	1.031	2.062	0.88	0.440	1.560	1.002	0.406
AS-20-GP	1.25	2.87	3.12	1.188	2.312	0.94	0.470	1.750	1.252	0.469
AS-24-GP	1.50	3.25	3.68	1.406	2.750	1.19	0.590	2.115	1.502	0.531
AS-32-GP	2.00	3.81	4.00	1.688	3.062	1.38	0.690	2.490	2.002	0.531
AS-40-GP	2.50	4.28	4.50	2.000	3.500	1.75	0.880	2.995	2.502	0.531
AS-48-GP	3.00	5.15	5.31	2.438	4.188	2.12	1.060	3.615	3.002	0.656
AS-56-GP	3.50	5.50	6.00	2.750	4.750	1.44	0.720	4.095	3.502	0.656
AS-64-GP	4.00	6.00	6.38	3.062	5.125	1.50	0.750	4.595	4.002	0.656

CODE 62 GAUGE PORT O-RING SPACER

PART NO.	PAD SIZE	A	B	C	D	E	F	G	H	J
ASX-8-GP	0.50	1.94	2.30	0.718	1.594	1.25	0.62	1.000	0.502	0.344
ASX-12-GP	0.75	2.50	2.95	0.937	2.000	1.25	0.62	1.250	0.752	0.406
ASX-16-GP	1.00	2.75	3.19	1.093	2.250	1.50	0.75	1.560	1.002	0.492
ASX-20-GP	1.25	3.06	3.75	1.250	2.625	1.50	0.75	1.750	1.252	0.531
ASX-24-GP	1.50	3.75	4.44	1.437	3.125	1.75	0.88	2.115	1.502	0.656
ASX-32-GP	2.00	4.50	5.25	1.750	3.812	1.75	0.88	2.490	2.002	0.781
ASX-40-GP	2.50	5.87	6.87	2.312	4.875	2.06	1.03	2.995	2.502	0.906
ASX-48-GP	3.00	7.00	8.50	2.812	6.000	2.62	1.31	3.615	3.002	1.156

BLANKING

**FLANGES -
CARBON STEEL**

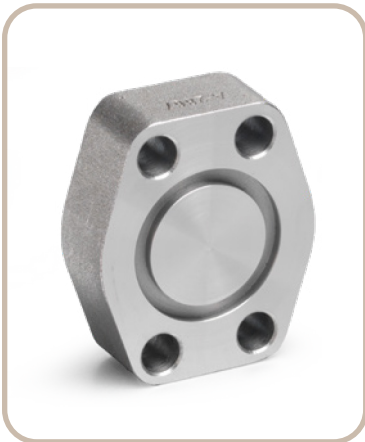

Figure 1

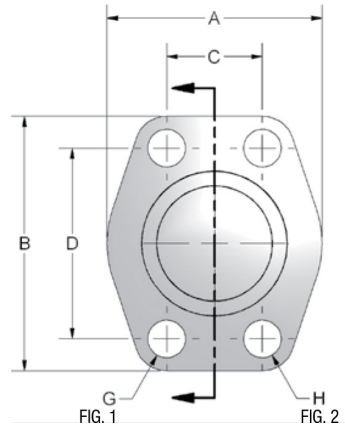

FIG. 1 FIG. 2

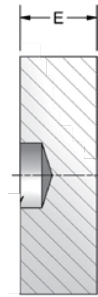

Figure 2

Location hole may be present on some parts but does not affect functionality.

- Mounting kit available on o-ring grooved flanges by simply adding suffix letter 'U' to part number.

CODE 61 BLANKING

PART NO. O-RING FIG. 1	PART NO. FLAT FACE FIG. 2	PAD SIZE	A	B	C	D	E	F	G	H UNC-2B	MOUNTING HARDWARE	
											O-RING	SHCS
W36-8-8	W37-8-8	0.50	1.813	2.125	0.688	1.50	0.75	1.000	0.344	5/16-18	210	5/16-18X1.50
W36-12-12	W37-12-12	0.75	2.063	2.563	0.875	1.875	0.75	1.250	0.406	3/8-16	214	3/8-16X1.50
W36-16-16	W37-16-16	1.00	2.313	2.750	1.031	2.063	0.88	1.560	0.406	3/8-16	219	3/8-16X1.75
W36-20-20	W37-20-20	1.25	2.875	3.125	1.188	2.313	0.94	1.750	0.469	7/16-14	222	7/16-14X1.75
W36-24-24	W37-24-24	1.50	3.250	3.688	1.406	2.750	1.19	2.115	0.531	1/2-13	225	1/2-13X2.25
W36-32-32	W37-32-32	2.00	3.813	4.000	1.688	3.063	1.44	2.490	0.531	1/2-13	228	1/2-13X2.50
W36-40-40	W37-40-40	2.50	4.281	4.500	2.000	3.500	1.82	2.995	0.531	1/2-13	232	1/2-13X2.75
W36-48-48	W37-48-48	3.00	5.156	5.313	2.438	4.188	2.19	3.615	0.656	5/8-11	237	5/8-11X3.50
W36-56-56	W37-56-56	3.50	5.500	6.000	2.750	4.750	1.44	4.095	0.656	5/8-11	241	5/8-11X2.75
W36-64-64	W37-64-64	4.00	6.00	6.38	3.062	5.125	1.44	4.595	0.656	5/8-11	245	5/8-11X2.75
W36-80-80	W37-80-80	5.00	7.12	7.25	3.625	6.000	1.75	5.595	0.656	5/8-11	253	5/8-11X3.00

CODE 62 BLANKING

PART NO. O-RING FIG. 1	PART NO. FLAT FACE FIG. 2	PAD SIZE	A	B	C	D	E	F	G	H UNC-2B	MOUNTING HARDWARE	
											O-RING	SHCS
W38-8-8	W39-8-8	0.500	1.94	2.30	0.718	1.594	1.25	1.000	0.344	5/16-18	210	5/16-18X2.00
W38-12-12	W39-12-12	0.750	2.50	2.95	0.937	2.000	1.25	1.250	0.406	3/8-16	214	3/8-16X2.00
W38-16-16	W39-16-16	1.00	2.75	3.19	1.093	2.250	1.50	1.560	0.492	7/16-14	219	7/16-14X2.50
W38-20-20	W39-20-20	1.25	3.06	3.75	1.250	2.625	1.43	1.750	0.531	1/2-13	222	1/2-13X2.50
W38-24-24	W39-24-24	1.50	3.75	4.44	1.437	3.125	1.82	2.115	0.656	5/8-11	225	5/8-11X3.00
W38-32-32	W39-32-32	2.00	4.50	5.25	1.750	3.812	1.82	2.490	0.781	3/4-10	228	3/4-10X3.00
W38-40-40	W39-40-40	2.50	5.87	6.87	2.311	4.874	1.93	2.995	0.906	7/8-9	232	7/8-9X3.50
W38-48-48	W39-48-48	3.00	7.00	8.50	2.811	6.000	2.69	3.615	1.190	1 1/8-7	237	1 1/8-7X4.50

ZERO PSI SHIPPING PLATE

FLANGES -
CARBON STEEL

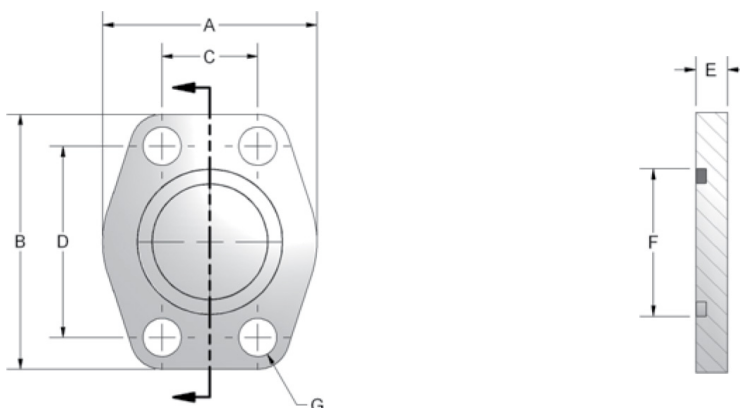

Trilex Fluid Power has developed a low cost solution to leaky, gasketless port covers. Forged steel shipping plates are 0.33" thick, silver trivalent plated for resistance to oxidation, and incorporate an o-ring groove on one side for "Zero Pressure" applications. The opposite side has a machined flat-face for capping off hose ends.

Applications Include: Cylinder Port Covers, Pump Port Covers, Stub-Out Header Line Covers, Maintenance Work and Great for Painting Protection.

CODE 61 MALE SHIPPING PLATE

PART NO.	**KIT PART NO.	PAD SIZE	A	B	C	D	E	F	G	MOUNTING HARDWARE	
										O-RING	HHCS
SP-8	SP-8U	0.50	1.81	2.12	0.688	1.500	0.33	1.000	0.344	210	5/16-18X.75
SP-12	SP-12U	0.75	2.06	2.56	0.875	1.875	0.33	1.250	0.413	214	3/8-16X.75
SP-16	SP-16U	1.00	2.31	2.75	1.031	2.063	0.33	1.560	0.413	219	3/8-16X.75
SP-20	SP-20U	1.25	2.88	3.12	1.188	2.313	0.33	1.750	0.469	222	7/16-14X.75
SP-24	SP-24U	1.50	3.25	3.69	1.406	2.750	0.33	2.115	0.531	225	1/2-13X.75
SP-32	SP-32U	2.00	3.81	4.00	1.688	3.063	0.33	2.490	0.531	228	1/2-13X.75
SP-40	SP-40U	2.50	4.28	4.50	2.000	3.500	0.33	2.995	0.531	232	1/2-13X.75
SP-48	SP-48U	3.00	5.16	5.31	2.438	4.188	0.33	3.615	0.656	237	5/8-11X1.00
SP-56	SP-56U	3.50	5.50	6.00	2.750	4.750	0.33	4.095	0.656	241	5/8-11X1.00
SP-64	SP-64U	4.00	6.00	6.38	3.062	5.125	0.33	4.595	0.656	245	5/8-11X1.00

**When ordering this part # you will receive:(1) shipping plate, (4) hex head bolts, and (1) Buna N O-Ring

CODE 62 MALE SHIPPING PLATE

PART NO.	**KIT PART NO.	PAD SIZE	A	B	C	D	E	F	G	MOUNTING HARDWARE	
										O-RING	HHCS
SPX-8	SPX-8U	0.50	1.94	2.19	0.718	1.594	0.33	1.000	0.354	210	5/16-18X.75
SPX-12	SPX-12U	0.75	2.50	2.81	0.937	2.000	0.33	1.250	0.433	214	3/8-16X.75
SPX-16	SPX-16U	1.00	2.75	3.19	1.093	2.250	0.33	1.560	0.531	219	7/16-14X.75
SPX-20	SPX-20U	1.25	3.06	3.75	1.250	2.625	0.33	1.750	0.610	222	1/2-13X.75
SPX-24	SPX-24U	1.50	3.75	4.44	1.437	3.125	0.33	2.115	0.689	225	5/8-11X1.00
SPX-32	SPX-32U	2.00	4.50	5.25	1.750	3.812	0.33	2.490	0.866	228	3/4-10X1.00
SPX-40	SPX-40U	2.50	5.87	6.87	2.311	4.874	0.33	2.995	0.984	232	7/8-9X1.00
SPX-48	SPX-48U	3.00	7.00	8.50	2.811	6.00	0.33	3.615	1.19	237	1 1/8-7X1.00

**When ordering this part # you will receive:(1) shipping plate, (4) hex head bolts, and (1) Buna N O-Ring

NOT FOR USE ON DYNAMIC OR PRESSURIZED APPLICATIONS

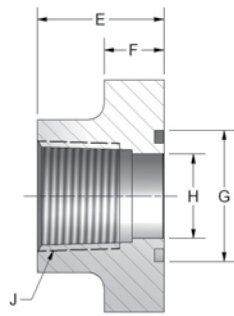

Figure 1

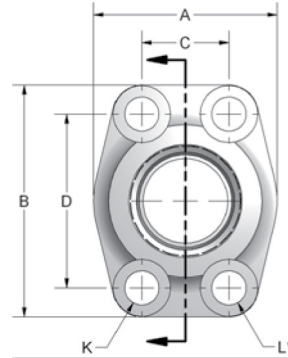

FIG. 1 FIG. 2

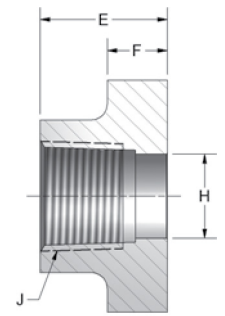

Figure 2

- Mounting kit available on o-ring grooved flanges by simply adding suffix letter 'U' to part number.

CODE 61 NPTF THREAD

PART NO. O-RING FIG. 1	PART NO. FLAT FACE FIG. 2	PORT SIZE	PAD SIZE	A	B	C	D	E	F	G	H	J	K	L UNC-2B	MOUNTING HARDWARE	
															O-RING	SHCS
W43-8-8	W104-8-8	0.50	0.50	1.81	2.13	0.688	1.500	1.42	0.63	1.000	0.502	1/2-14	0.344	5/16-18	210	5/16-18X1.25
W43-12-12	W104-12-12	0.75	0.75	1.97	2.56	0.875	1.875	1.42	0.71	1.250	0.752	3/4-14	0.406	3/8-16	214	3/8-16X1.50
W43-16-16	W104-16-16	1.00	1.00	2.17	2.75	1.031	2.062	1.50	0.71	1.560	1.002	1-11.5	0.406	3/8-16	219	3/8-16X1.50
W43-20-20	W104-20-20	1.25	1.25	2.68	3.12	1.188	2.312	1.61	0.83	1.750	1.252	1 1/4-11.5	0.469	7/16-14	222	7/16-14X1.75
W43-24-24	W104-24-24	1.50	1.50	3.07	3.66	1.406	2.750	1.77	0.98	2.115	1.502	1 1/2-11.5	0.531	1/2-13	225	1/2-13X1.75
W43-32-32	W104-32-32	2.00	2.00	3.54	4.00	1.688	3.062	1.77	0.98	2.490	2.002	2-11.5	0.531	1/2-13	228	1/2-13X1.75
W43-40-40	W104-40-40	2.50	2.50	4.09	4.49	2.000	3.500	1.97	0.98	2.995	2.502	2 1/2-8	0.531	1/2-13	232	1/2-13X1.75
W43-48-48	W104-48-48	3.00	3.00	4.88	5.28	2.438	4.188	1.97	1.06	3.615	3.002	3-8	0.656	5/8-11	237	5/8-11X2.00
W43-56-56	W104-56-56	3.50	3.50	5.35	5.98	2.750	4.750	2.19	1.06	4.095	3.500	3 1/2-8	0.656	5/8-11	241	5/8-11X2.00
W43-64-64	W104-64-64	4.00	4.00	5.75	6.38	3.062	5.125	2.19	1.06	4.595	3.940	4-8	0.656	5/8-11	245	5/8-11X2.00

CODE 62 NPTF THREAD

PART NO. O-RING FIG. 1	PART NO. FLAT FACE FIG. 2	PORT SIZE	PAD SIZE	A	B	C	D	E	F	G	H	J	K	L UNC-2B	MOUNTING HARDWARE	
															O-RING	SHCS
W44-8-8	W45-8-8	0.50	0.50	1.81	2.21	0.718	1.594	1.42	0.63	1.000	0.502	1/2-14	0.344	5/6-18	210	5/16-18X1.25
W44-12-12	W45-12-12	0.75	0.75	2.17	2.80	0.937	2.000	1.38	0.83	1.250	0.752	3/4-14	0.406	3/8-16	214	3/8-16X1.50
W44-16-16	W45-16-16	1.00	1.00	2.56	3.19	1.093	2.250	1.65	0.98	1.560	1.002	1-11.5	0.492	7/16-14	219	7/16-14X1.75
W44-20-20	W45-20-20	1.25	1.25	3.07	3.75	1.250	2.625	1.77	1.06	1.750	1.252	1 1/4-11.5	0.531	1/2-13	222	1/2-13X1.75
W44-24-24	W45-24-24	1.50	1.50	3.70	4.41	1.437	3.125	1.97	1.18	2.115	1.502	1 1/2-11.5	0.656	5/8-11	225	5/8-11X2.25
W44-32-32	W45-32-32	2.00	2.00	4.50	5.28	1.750	3.812	2.56	1.46	2.490	2.002	2-11.5	0.781	3/4-10	228	3/4-10X2.75

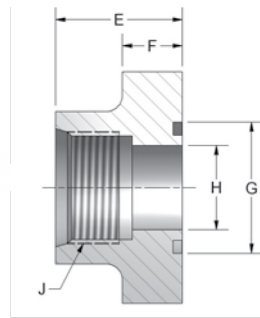

Figure 1

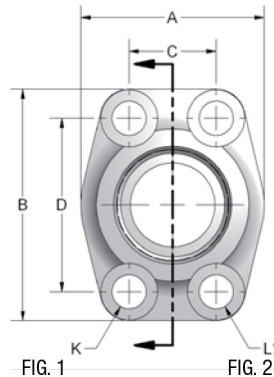

FIG. 1

FIG. 2

*No Spotface

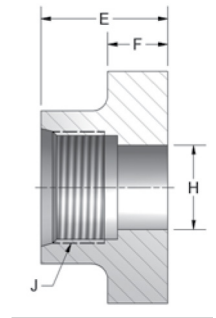

Figure 2

- Mounting kit available on o-ring grooved flanges by simply adding suffix letter 'U' to part number.

CODE 61 SAE STRAIGHT THREAD

PART NO. O-RING FIG. 1	PART NO. FLAT FACE FIG. 2	PORT SIZE	PAD SIZE	A	B	C	D	E	F	G	H	J	K	L UNC-2B	MOUNTING HARDWARE	
															O-RING	SHCS
W46-8-8	W106-8-8	0.50	0.50	1.81	2.13	0.688	1.500	1.42	0.63	1.000	0.502	3/4-16	0.344	5/16-18	210	5/16-18X1.25
W46-12-12	W106-12-12	0.75	0.75	1.97	2.56	0.875	1.875	1.42	0.71	1.250	0.752	1 1/16-12	0.406	3/8-16	214	3/8-16X1.50
W46-16-16	W106-16-16	1.00	1.00	2.17	2.75	1.031	2.062	1.50	0.71	1.560	1.002	1 5/16-12	0.406	3/8-16	219	3/8-16X1.50
W46-20-20	W106-20-20	1.25	1.25	2.68	3.12	1.188	2.312	1.61	0.83	1.750	1.252	1 5/8-12	0.469	7/16-14	222	7/16-14X1.75
W46-24-24	W106-24-24	1.50	1.50	3.07	3.66	1.406	2.750	1.77	0.98	2.115	1.502	1 7/8-12	0.531	1/2-13	225	1/2-13X1.75
*W46-32-32	W106-32-32	2.00	2.00	3.54	4.00	1.688	3.062	1.77	0.98	2.490	2.002	2 1/2-12	0.531	1/2-13	228	1/2-13X1.75
**W46-40-40	W106-40-40	2.50	2.50	4.09	4.49	2.000	3.500	1.97	0.98	3.000	2.500	3-12	0.530	1/2-13	232	1/2-13X1.75
**W46-48-48	W106-48-48	3.00	3.00	4.88	5.28	2.440	4.190	1.97	1.06	3.620	3.000	3 1/2-12	0.660	5/8-11	237	5/8-11X2.00
**W46-64-64	W106-64-64	4.00	4.00	5.74	6.38	3.060	5.130	2.19	1.06	4.600	4.000	4 1/2-12	0.660	5/8-11	245	5/8-11X2.00

*1000 PSI max for W46-32-32

** Consult Factory For Working Pressure

CODE 62 SAE STRAIGHT THREAD

PART NO. O-RING FIG. 1	PART NO. FLAT FACE FIG. 2	PORT SIZE	PAD SIZE	A	B	C	D	E	F	G	H	J	K	L UNC-2B	MOUNTING HARDWARE	
															O-RING	SHCS
W48-8-8	W49-8-8	0.50	0.50	1.81	2.21	0.718	1.594	1.42	0.63	1.000	0.502	3/4-16	0.344	5/16-18	210	5/16-18X1.25
W48-12-12	W49-12-12	0.75	0.75	2.17	2.80	0.937	2.000	1.38	0.83	1.250	0.752	1 1/16-12	0.406	3/8-16	214	3/8-16X1.50
W48-16-16	W49-16-16	1.00	1.00	2.56	3.19	1.093	2.250	1.65	0.98	1.560	1.002	1 5/16-12	0.492	7/16-14	219	7/16-14X1.75
W48-20-20	W49-20-20	1.25	1.25	3.07	3.75	1.250	2.625	1.77	1.06	1.750	1.252	1 5/8-12	0.531	1/2-13	222	1/2-13X1.75
W48-24-24	W49-24-24	1.50	1.50	3.70	4.41	1.437	3.125	1.97	1.18	2.115	1.502	1 7/8-12	0.656	5/8-11	225	5/8-11X2.25
W48-32-32	W49-32-32	2.00	2.00	4.50	5.28	1.750	3.812	2.56	1.46	2.490	2.002	2 1/2-12	0.781	3/4-10	228	3/4-10X2.75

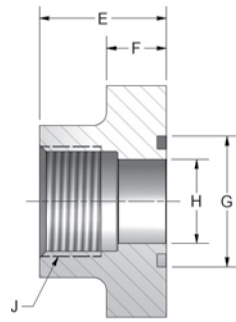

Figure 1

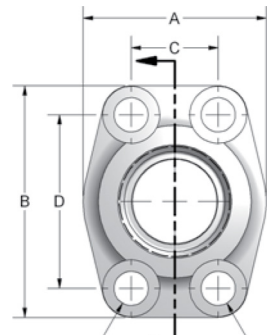

FIG. 1

FIG. 2

*No Spotface

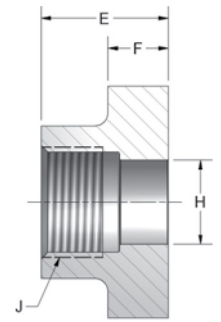

Figure 2

- Mounting kit available on o-ring grooved flanges by simply adding suffix letter 'U' to part number.

CODE 61 BSPB THREAD

PART NO. O-RING FIG. 1	PART NO. FLAT FACE FIG. 2	PORT SIZE	PAD SIZE	A	B	C	D	E	F	G	H	J BSPB	K	L UNC-2B	MOUNTING HARDWARE	
															O-RING	SHCS
W192-8-8	W193-8-8	0.50	0.50	1.81	2.13	0.688	1.500	1.42	0.63	1.000	0.502	0.50-14	0.344	5/16-18	210	5/16-18X1.25
W192-12-12	W193-12-12	0.75	0.75	1.97	2.56	0.875	1.875	1.42	0.71	1.250	0.752	0.75-14	0.406	3/8-16	214	3/8-16X1.50
W192-16-16	W193-16-16	1.00	1.00	2.17	2.75	1.031	2.062	1.50	0.71	1.560	1.002	1.00-11	0.406	3/8-16	219	3/8-16X1.50
W192-20-20	W193-20-20	1.25	1.25	2.68	3.12	1.188	2.312	1.61	0.83	1.750	1.252	1.25-11	0.469	7/16-14	222	7/16-14X1.75
W192-24-24	W193-24-24	1.50	1.50	3.07	3.66	1.406	2.750	1.77	0.98	2.115	1.502	1.50-11	0.531	1/2-13	225	1/2-13X1.75
W192-32-32	W193-32-32	2.00	2.00	3.54	4.00	1.688	3.062	1.77	0.98	2.490	2.002	2.00-11	0.531	1/2-13	228	1/2-13X1.75

CODE 62 BSPB THREAD

PART NO. O-RING FIG. 1	PART NO. FLAT FACE FIG. 2	PORT SIZE	PAD SIZE	A	B	C	D	E	F	G	H	J BSPB	K	L UNC-2B	MOUNTING HARDWARE	
															O-RING	SHCS
W194-8-8	W195-8-8	0.50	0.50	1.81	2.21	0.718	1.594	1.42	0.63	1.000	0.502	0.50-14	0.344	5/16-18	210	5/16-18X1.25
W194-12-12	W195-12-12	0.75	0.75	2.17	2.80	0.937	2.000	1.38	0.83	1.250	0.752	0.75-14	0.406	3/8-16	214	3/8-16X1.50
W194-16-16	W195-16-16	1.00	1.00	2.56	3.19	1.093	2.250	1.65	0.98	1.560	1.002	1.00-11	0.492	7/16-14	219	7/16-14X1.75
W194-20-20	W195-20-20	1.25	1.25	3.07	3.75	1.250	2.625	1.77	1.06	1.750	1.252	1.25-11	0.531	1/2-13	222	1/2-13X1.50
W194-24-24	W195-24-24	1.50	1.50	3.70	4.41	1.437	3.125	1.97	1.18	2.115	1.502	1.50-11	0.656	5/8-11	225	5/8-11X2.25
W194-32-32	W195-32-32	2.00	2.00	4.50	5.28	1.750	3.812	2.56	1.46	2.490	2.002	2.00-11	0.781	3/4-10	228	3/4-10X2.75

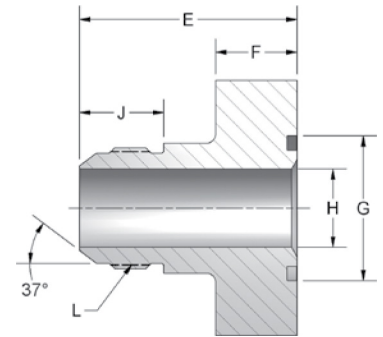
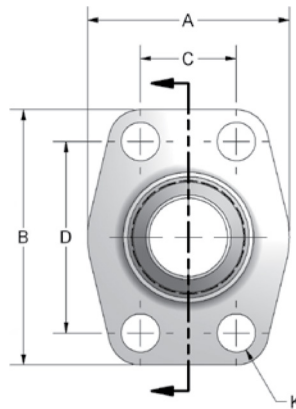

- 4-Bolt Flange hole pattern per SAE J518. Male JIC Thread per SAE J514.
- Mounting kit available on o-ring grooved flanges by simply adding suffix letter 'U' to part number.

CODE 61 MALE JIC

PART NO.	PAD SIZE	A	B	C	D	E	F	G	H	J	K	L	MOUNTING HARDWARE	
													O-RING	SHCS
W300-8-8	0.50	1.81	2.13	0.688	1.500	2.00	0.88	1.000	0.391	0.657	0.344	3/4-16	210	5/16-18X1.50
W300-12-12	0.75	1.97	2.56	0.875	1.875	2.29	0.88	1.250	0.609	0.864	0.413	1 1/16-12	214	3/8-16X1.50
W300-16-16	1.00	2.17	2.75	1.031	2.062	2.35	0.88	1.560	0.844	0.911	0.413	1 5/16-12	219	3/8-16X1.50
W300-20-20	1.25	2.68	3.12	1.188	2.312	2.49	0.88	1.750	1.078	0.958	0.469	1 5/8-12	222	7/16-14X1.75
W300-24-24	1.50	3.07	3.66	1.406	2.750	2.81	0.98	2.115	1.312	1.083	0.531	1 7/8-12	225	1/2-13X1.75

CODE 62 MALE JIC

PART NO.	PAD SIZE	A	B	C	D	E	F	G	H	J	K	L	MOUNTING HARDWARE	
													O-RING	SHCS
W600-8-8	0.50	1.81	2.21	0.719	1.594	1.75	0.88	1.000	0.391	0.657	0.344	3/4-16	210	5/16-18X1.50
W600-12-12	0.75	2.17	2.80	0.937	2.000	2.31	0.88	1.250	0.609	0.864	0.413	1-1/16-12	214	3/8-16X1.50
W600-16-16	1.00	2.56	3.19	1.093	2.250	2.62	0.98	1.560	0.844	0.911	0.492	1-5/16-12	219	7/16-14X1.75
W600-20-20	1.25	3.07	3.75	1.250	2.625	2.81	1.06	1.750	1.078	0.958	0.531	1-5/8-12	222	1/2-13X1.75
W600-24-24	1.50	3.70	4.41	1.437	3.125	3.25	1.18	2.115	1.312	1.083	0.656	1-7/8-12	225	5/8-11X2.25

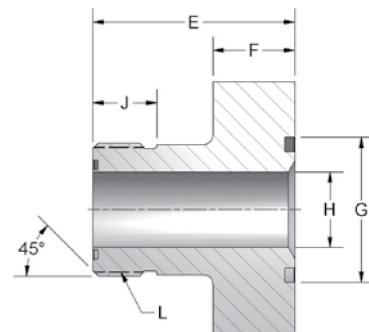
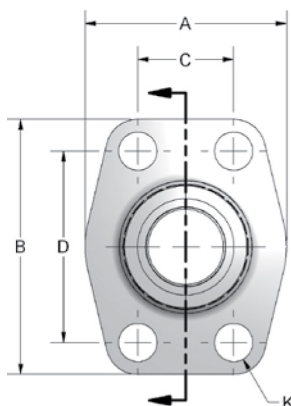

- 4-Bolt Flange hole thread per SAE J518. Male ORFS Thread per SAE J1453-1.
- Mounting kit available on o-ring grooved flanges by simply adding suffix letter 'U' to part number.

CODE 61 MALE ORFS

PART NO.	PAD SIZE	A	B	C	D	E	F	G	H	J	K	L	MOUNTING HARDWARE	
													O-RING	SHCS
W304-8-8	0.50	1.81	2.13	0.688	1.500	1.75	0.88	1.000	0.374	0.512	0.344	13/16-16	210	5/16-18X1.50
W304-12-12	0.75	1.97	2.56	0.875	1.875	2.00	0.88	1.250	0.611	0.670	0.413	1 3/16-12	214	3/8-16X1.50
W304-16-16	1.00	2.17	2.75	1.031	2.062	2.00	0.88	1.560	0.807	0.689	0.413	1 7/16-12	219	3/8-16X1.50
W304-20-20	1.25	2.68	3.12	1.188	2.312	2.25	0.88	1.750	1.024	0.689	0.469	1 11/16-12	222	7/16-14X1.75
W304-24-24	1.50	3.07	3.66	1.406	2.750	2.50	0.98	2.115	1.260	0.689	0.531	2-12	225	1/2-13X2.00

CODE 62 MALE ORFS

PART NO.	PAD SIZE	A	B	C	D	E	F	G	H	J	K	L	MOUNTING HARDWARE	
													O-RING	SHCS
W604-8-8	0.50	1.81	2.21	0.719	1.594	1.75	0.88	1.000	0.374	0.512	0.344	13/16-16	210	5/16-18X1.50
W604-12-12	0.75	2.17	2.80	0.937	2.000	2.25	0.88	1.250	0.611	0.670	0.413	1 3/16-12	214	3/8-16X1.50
W604-16-16	1.00	2.56	3.19	1.093	2.250	2.50	0.98	1.560	0.807	0.689	0.492	1 7/16-12	219	7/16-14X1.75
W604-20-20	1.25	3.07	3.75	1.250	2.625	2.62	1.06	1.750	1.024	0.689	0.531	1 11/16-12	222	1/2-13X1.75
W604-24-24	1.50	3.70	4.41	1.437	3.125	2.88	1.18	2.115	1.260	0.689	0.656	2-12	225	5/8-11X2.25

FLAT SOCKET WELD PIPE

FLANGES -
CARBON STEEL

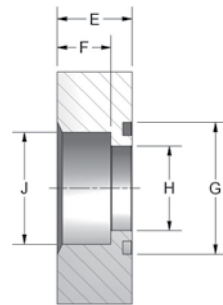

Figure 1

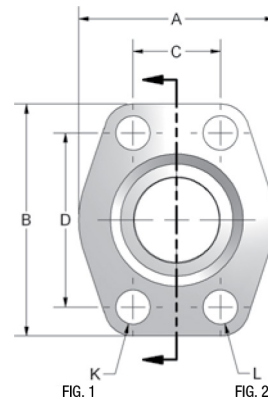

FIG. 1

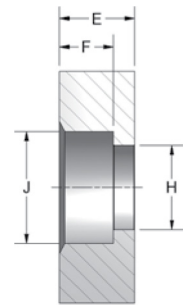

Figure 2

- Mounting kit available on o-ring grooved flanges by simply adding suffix letter 'U' to part number.

CODE 61 FLAT SOCKET WELD - PIPE

PART NO. O-RING FIG. 1	PART NO. FLAT FACE FIG. 2	PIPE SIZE	PAD SIZE	A	B	C	D	E	F	G	H	J	K	L	MOUNTING HARDWARE	
															O-RING	SHCS
W4-8-8	W61-8-8	0.50	0.50	1.813	2.125	0.688	1.500	0.750	0.560	1.000	0.502	0.855	0.344	5/16-18	210	5/16-18X1.50
W4-12-12	W61-12-12	0.75	0.75	2.063	2.563	0.875	1.875	0.750	0.560	1.250	0.752	1.062	0.406	3/8-16	214	3/8-16X1.50
W4-16-16	W61-16-16	1.00	1.00	2.313	2.750	1.031	2.063	0.880	0.630	1.560	1.002	1.328	0.406	3/8-16	219	3/8-16X1.75
W4-20-20	W61-20-20	1.25	1.25	2.875	3.125	1.188	2.313	0.940	0.690	1.750	1.252	1.672	0.469	7/16-14	222	7/16-14X1.75
W4-24-24	W61-24-24	1.50	1.50	3.250	3.688	1.406	2.750	1.190	0.750	2.115	1.502	1.922	0.531	1/2-13	225	1/2-13X2.25
W4-32-32	W61-32-32	2.00	2.00	3.813	4.000	1.688	3.063	1.380	0.875	2.490	2.002	2.406	0.531	1/2-13	228	1/2-13X2.50
W4-40-40	W61-40-40	2.50	2.50	4.281	4.500	2.000	3.500	1.750	1.000	2.995	2.502	2.906	0.531	1/2-13	232	1/2-13X2.75
W4-48-48	W61-48-48	3.00	3.00	5.156	5.313	2.438	4.188	2.120	1.250	3.615	3.002	3.547	0.656	5/8-11	237	5/8-11X3.50

CODE 62 FLAT SOCKET WELD - PIPE

PART NO. O-RING FIG. 1	PART NO. FLAT FACE FIG. 2	PIPE SIZE	PAD SIZE	A	B	C	D	E	F	G	H	J	K	L	MOUNTING HARDWARE	
															O-RING	SHCS
W59-8-8	W60-8-8	0.50	0.50	1.94	2.30	0.718	1.594	1.25	0.560	1.000	0.502	0.855	0.344	5/16-18	210	5/16-18X2.00
W59-12-12	W60-12-12	0.75	0.75	2.50	2.95	0.937	2.000	1.250	0.560	1.250	0.752	1.062	0.406	3/8-16	214	3/8-16X2.00
W59-16-16	W60-16-16	1.00	1.00	2.75	3.19	1.093	2.250	1.500	0.630	1.560	1.002	1.328	0.492	7/16-14	219	7/16-14X2.50
W59-20-20	W60-20-20	1.25	1.25	3.06	3.75	1.250	2.625	1.500	0.690	1.750	1.252	1.672	0.531	1/2-13	222	1/2-13X2.50
W59-24-24	W60-24-24	1.50	1.50	3.75	4.44	1.437	3.125	1.750	0.750	2.115	1.502	1.922	0.656	5/8-11	225	5/8-11X3.00
W59-32-32	W60-32-32	2.00	2.00	4.50	5.25	1.750	3.812	1.750	0.875	2.490	2.002	2.406	0.781	3/4-10	228	3/4-10X3.00
W59-40-40	W60-40-40	2.50	2.50	5.87	6.87	2.311	4.874	2.060	1.000	2.995	2.502	2.906	0.906	7/8-9	232	**7/8-9X3.50
W59-48-48	W60-48-48	3.00	3.00	7.00	8.50	2.811	6.000	2.620	1.250	3.615	3.002	3.547	1.190	1-1/8-7	237	**1 1/8-7X4.50

**HHCS

CODE 61 FLAT SOCKET WELD - PIPE - ALL SIZES 500 PSI

PART NO. O-RING FIG. 1	PART NO. FLAT FACE FIG. 2	PIPE SIZE	PAD SIZE	A	B	C	D	E	F	G	H	J	K	L	MOUNTING HARDWARE	
															O-RING	SHCS
W72-48-48	W91-48-48	3.00	3.00	5.12	5.31	2.438	4.188	1.380	1.120	3.615	3.002	3.547	0.656	5/8-11	237	5/8-11X2.50
W72-56-56	W91-56-56	3.50	3.50	5.50	6.00	2.750	4.750	1.440	1.190	4.095	3.502	4.047	0.656	5/8-11	241	5/8-11X2.75
W72-64-64	W91-64-64	4.00	4.00	6.00	6.38	3.062	5.125	1.500	1.250	4.595	4.002	4.578	0.656	5/8-11	245	5/8-11X2.75
W72-80-80	W91-80-80	5.00	5.00	7.12	7.25	3.625	6.000	1.750	1.380	5.595	5.002	5.641	0.656	5/8-11	253	5/8-11X3.00

FLAT SOCKET WELD TUBE

FLANGES -
CARBON STEEL

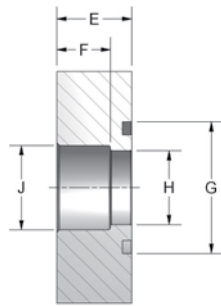
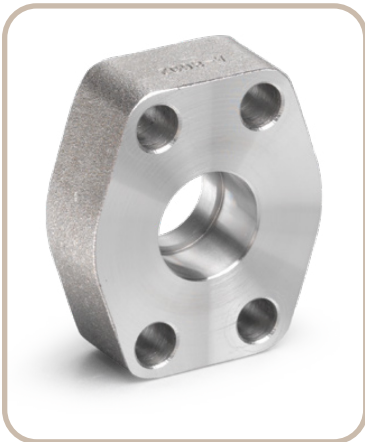

Figure 1

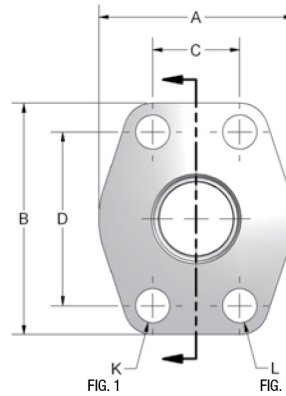

FIG. 1 FIG. 2

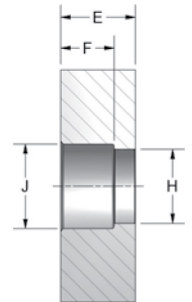

Figure 2

- Mounting kit available on o-ring grooved flanges by simply adding suffix letter 'U' to part number.

CODE 61 FLAT SOCKET WELD - TUBE

PART NO. O-RING FIG. 1	PART NO. FLAT FACE FIG. 2	PIPE SIZE	PAD SIZE	A	B	C	D	E	F	G	H	J	K	L	MOUNTING HARDWARE	
															O-RING	SHCS
W6-12-12	W62-12-12	0.75	0.75	2.060	2.560	0.875	1.875	0.750	0.560	1.250	0.625	0.752	0.406	3/8-16	214	3/8-16X1.50
W6-16-12	W62-16-12	1.00	0.75	2.060	2.560	0.875	1.875	0.750	0.560	1.250	0.750	1.002	0.406	3/8-16	214	3/8-16X1.50
W6-16-16	W62-16-16	1.00	1.00	2.310	2.750	1.031	2.062	0.880	0.630	1.560	0.875	1.002	0.406	3/8-16	219	3/8-16X1.75
W6-20-16	W62-20-16	1.25	1.00	2.310	2.750	1.031	2.062	0.880	0.630	1.560	1.000	1.252	0.406	3/8-16	219	3/8-16X1.75
W6-20-20	W62-20-20	1.25	1.25	2.880	3.120	1.188	2.312	0.940	0.690	1.750	1.125	1.252	0.469	7/16-14	222	7/16-14X1.75
W6-24-20	W62-24-20	1.50	1.25	2.880	3.120	1.188	2.312	0.940	0.690	1.750	1.250	1.502	0.469	7/16-14	222	7/16-14X1.75
W6-24-24	W62-24-24	1.50	1.50	3.250	3.690	1.406	2.750	1.190	0.750	2.115	1.375	1.502	0.531	1/2-13	225	1/2-13X2.25
W6-28-24	W62-28-24	1.75	1.50	3.250	3.690	1.406	2.750	1.190	0.750	2.115	1.500	1.752	0.531	1/2-13	225	1/2-13X2.25
W6-32-32	W62-32-32	2.00	2.00	3.810	4.000	1.688	3.062	1.380	0.875	2.490	1.875	2.002	0.531	1/2-13	228	1/2-13X2.50
W6-36-32	W62-36-32	2.25	2.00	3.810	4.000	1.688	3.062	1.380	0.875	2.490	2.000	2.252	0.531	1/2-13	228	1/2-13X2.50

CODE 62 FLAT SOCKET WELD - TUBE

PART NO. O-RING FIG. 1	PART NO. FLAT FACE FIG. 2	PIPE SIZE	PAD SIZE	A	B	C	D	E	F	G	H	J	K	L	MOUNTING HARDWARE	
															O-RING	SHCS
W58-12-12	W63-12-12	0.75	0.75	2.50	2.95	0.937	2.000	1.250	0.560	1.250	0.625	0.752	0.406	3/8-16	214	3/8-16X2.00
W58-16-12	W63-16-12	1.00	0.75	2.50	2.95	0.937	2.000	1.250	0.560	1.250	0.750	1.002	0.406	3/8-16	214	3/8-16X2.00
W58-16-16	W63-16-16	1.00	1.00	2.75	3.19	1.093	2.250	1.500	0.630	1.560	0.875	1.002	0.492	7/16-14	219	7/16-14X2.50
W58-20-16	W63-20-16	1.25	1.00	2.75	3.19	1.093	2.250	1.500	0.630	1.560	1.000	1.252	0.492	7/16-14	219	7/16-14X2.50
W58-20-20	W63-20-20	1.25	1.25	3.06	3.75	1.250	2.625	1.500	0.690	1.750	1.125	1.252	0.531	1/2-13	222	1/2-13X2.50
W58-24-20	W63-24-20	1.50	1.25	3.06	3.75	1.250	2.625	1.500	0.690	1.750	1.250	1.502	0.531	1/2-13	222	1/2-13X2.50
W58-24-24	W63-24-24	1.50	1.50	3.75	4.44	1.437	3.125	1.750	0.750	2.115	1.375	1.502	0.656	5/8-11	225	5/8-11X3.00
W58-28-24	W63-28-24	1.75	1.50	3.75	4.44	1.437	3.125	1.750	0.750	2.115	1.500	1.752	0.656	5/8-11	225	5/8-11X3.00
W58-32-32	W63-32-32	2.00	2.00	4.50	5.25	1.750	3.812	1.750	0.875	2.490	1.875	2.002	0.781	3/4-10	228	3/4-10X3.00
W58-36-32	W63-36-32	2.25	2.00	4.50	5.25	1.750	3.812	1.750	0.875	2.490	2.000	2.252	0.781	3/4-10	228	3/4-10X3.00

DEEP SOCKET WELD PIPE

FLANGES -
CARBON STEEL

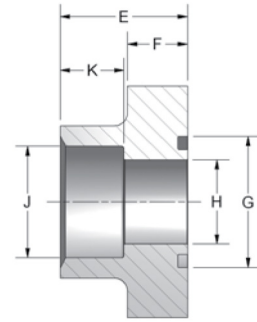

Figure 1

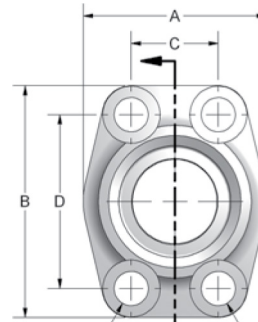

FIG. 1

FIG. 2

*No Spotface

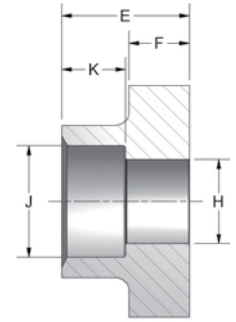

Figure 2

- Mounting kit available on o-ring grooved flanges by simply adding suffix letter 'U' to part number.

CODE 61 DEEP SOCKET WELD - PIPE

PART NO. O-RING FIG. 1	PART NO. FLAT FACE FIG. 2	PIPE SIZE	PAD SIZE	A	B	C	D	E	F	G	H	J	K	L	M UNC-2B	MOUNTING HARDWARE	
																O-RING	SHCS
W31-8-8	W3-8-8	0.50	0.50	1.81	2.13	0.688	1.500	1.42	0.63	1.000	0.502	0.855	0.75	0.344	5/16-18	210	5/16-18X1.25
W31-12-12	W3-12-12	0.75	0.75	1.97	2.56	0.875	1.875	1.42	0.71	1.250	0.752	1.062	0.75	0.406	3/8-16	214	3/8-16X1.50
W31-16-16	W3-16-16	1.00	1.00	2.17	2.75	1.031	2.062	1.50	0.71	1.560	1.002	1.328	0.75	0.406	3/8-16	219	3/8-16X1.50
W31-20-20	W3-20-20	1.25	1.25	2.68	3.12	1.188	2.312	1.61	0.83	1.750	1.252	1.672	0.87	0.469	7/16-14	222	7/16-14X1.75
W31-24-24	W3-24-24	1.50	1.50	3.07	3.66	1.406	2.750	1.77	0.98	2.115	1.502	1.922	0.94	0.531	1/2-13	225	1/2-13X1.75
W31-32-32	W3-32-32	2.00	2.00	3.54	4.00	1.688	3.062	1.77	0.98	2.490	2.002	2.406	1.02	0.531	1/2-13	228	1/2-13X1.75
W31-40-40	W3-40-40	2.50	2.50	4.09	4.49	2.000	3.500	1.97	0.98	2.995	2.502	2.908	1.18	0.531	1/2-13	232	1/2-13X1.75
W31-48-48	W3-48-48	3.00	3.00	4.88	5.28	2.438	4.188	1.97	1.06	3.615	3.002	3.547	1.34	0.656	5/8-11	237	5/8-11X2.00

CODE 62 DEEP SOCKET WELD - PIPE

PART NO. O-RING FIG. 1	PART NO. FLAT FACE FIG. 2	PIPE SIZE	PAD SIZE	A	B	C	D	E	F	G	H	J	K	L	M UNC-2B	MOUNTING HARDWARE	
																O-RING	SHCS
W81-8-8	W80-8-8	0.50	0.50	1.81	2.21	0.718	1.594	1.42	0.63	1.000	0.502	0.855	0.75	0.344	5/16-18	210	5/16-18X1.25
W81-12-12	W80-12-12	0.75	0.75	2.17	2.80	0.937	2.000	1.38	0.83	1.250	0.752	1.062	0.87	0.406	3/8-16	214	3/8-16X1.50
W81-16-16	W80-16-16	1.00	1.00	2.56	3.19	1.093	2.250	1.65	0.98	1.560	1.002	1.328	0.87	0.492	7/16-14	219	7/16-14X1.75
W81-20-20	W80-20-20	1.25	1.25	3.07	3.75	1.250	2.625	1.77	1.06	1.750	1.252	1.672	0.98	0.531	1/2-13	222	1/2-13X1.75
W81-24-24	W80-24-24	1.50	1.50	3.70	4.41	1.437	3.125	1.97	1.18	2.115	1.502	1.922	1.10	0.656	5/8-11	225	5/8-11X2.25
W81-32-32	W80-32-32	2.00	2.00	4.50	5.28	1.750	3.812	2.56	1.46	2.490	2.002	2.406	0.94	0.781	3/4-10	228	3/4-10X2.75

DEEP SOCKET WELD TUBE

FLANGES -
CARBON STEEL

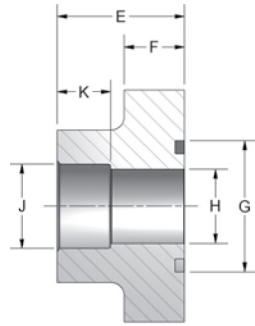
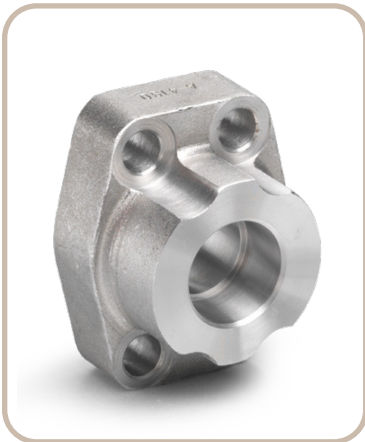

Figure 1

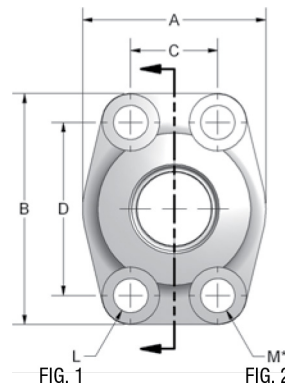

FIG. 1 FIG. 2
*No Spotface

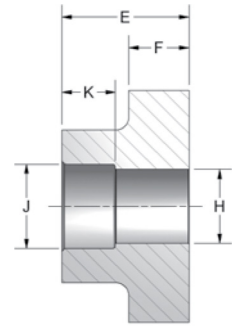

Figure 2

- Mounting kit available on o-ring grooved flanges by simply adding suffix letter 'U' to part number.

CODE 61 DEEP SOCKET WELD - TUBE

PART NO. O-RING FIG. 1	PART NO. FLAT FACE FIG. 2	PIPE SIZE	PAD SIZE	A	B	C	D	E	F	G	H	J	K	L	M UNC-2B	MOUNTING HARDWARE	
																O-RING	SHCS
W51-12-12	W5-12-12	0.75	0.75	1.97	2.56	0.875	1.875	1.42	0.71	1.250	0.625	0.752	0.560	0.406	3/8-16	214	3/8-16X1.50
W51-16-12	W5-16-12	1.00	0.75	1.97	2.56	0.875	1.875	1.42	0.71	1.250	0.750	1.002	0.560	0.406	3/8-16	214	3/8-16X1.50
W51-16-16	W5-16-16	1.00	1.00	2.17	2.75	1.031	2.062	1.50	0.71	1.560	0.875	1.002	0.630	0.406	3/8-16	219	3/8-16X1.50
W51-20-16	W5-20-16	1.25	1.00	2.17	2.75	1.031	2.062	1.50	0.71	1.560	1.000	1.252	0.630	0.406	3/8-16	219	3/8-16X1.50
W51-20-20	W5-20-20	1.25	1.25	2.68	3.12	1.188	2.312	1.61	0.83	1.750	1.125	1.252	0.690	0.469	7/16-14	222	7/16-14X1.75
W51-24-20	W5-24-20	1.50	1.25	2.68	3.12	1.188	2.312	1.61	0.83	1.750	1.250	1.502	0.690	0.469	7/16-14	222	7/16-14X1.75
W51-24-24	W5-24-24	1.50	1.50	3.07	3.66	1.406	2.750	1.77	0.98	2.115	1.375	1.502	0.750	0.531	1/2-13	225	1/2-13X1.75
W51-28-24	W5-28-24	1.75	1.50	3.07	3.66	1.406	2.750	1.77	0.98	2.115	1.500	1.752	0.750	0.531	1/2-13	225	1/2-13X1.75
W51-32-32	W5-32-32	2.00	2.00	3.54	4.00	1.688	3.062	1.77	0.98	2.490	1.875	2.002	0.870	0.531	1/2-13	228	1/2-13X1.75
W51-36-32	W5-36-32	2.25	2.00	3.54	4.00	1.688	3.062	1.77	0.98	2.490	2.000	2.252	0.870	0.531	1/2-13	228	1/2-13X1.75
W51-40-40	W5-40-40	2.50	2.50	4.09	4.49	2.000	3.500	1.97	0.98	2.995	2.375	2.502	1.000	0.531	1/2-13	232	1/2-13X1.75
W51-44-40	W5-44-40	2.75	2.50	4.09	4.49	2.000	3.500	1.97	0.98	2.995	2.500	2.752	1.000	0.531	1/2-13	232	1/2-13X1.75

BUTT WELD PIPE

FLANGES -
CARBON STEEL

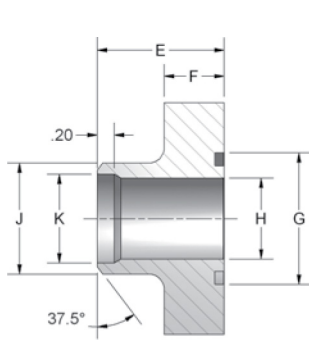

Figure 1

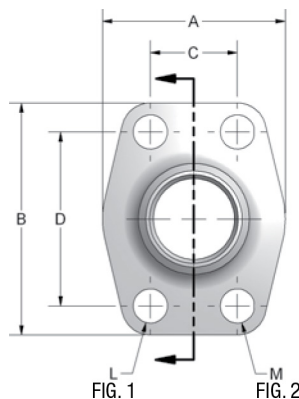

FIG. 1

FIG. 2

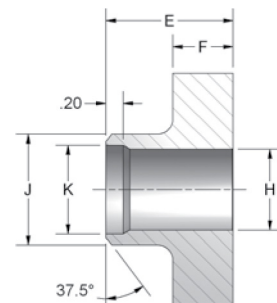

Figure 2

- NOTE: Also available in sizes 3 1/2", 4", and 5". Please contact Trilex for specifications.
- Mounting kit available on o-ring grooved flanges by simply adding suffix letter 'U' to part number.

CODE 61 BUTT WELD - SCHEDULE 40 PIPE

PART NO. O-RING FIG. 1	PART NO. FLAT FACE FIG. 2	PIPE SIZE	PAD SIZE	A	B	C	D	E	F	G	H	J	K	L	M UNC-2B	MOUNTING HARDWARE	
																O-RING	SHCS
W35-8	W34-8	0.50	0.50	1.81	2.13	0.688	1.500	1.42	0.63	1.000	0.548	0.840	0.624	0.344	5/16-18	210	5/16-18X1.25
W35-12	W34-12	0.75	0.75	1.97	2.56	0.875	1.875	1.42	0.71	1.250	0.744	1.050	0.846	0.406	3/8-16	214	3/8-16X1.50
W35-16	W34-16	1.00	1.00	2.17	2.75	1.031	2.062	1.50	0.71	1.560	0.959	1.315	1.051	0.406	3/8-16	219	3/8-16X1.50
W35-20	W34-20	1.25	1.25	2.68	3.12	1.188	2.312	1.61	0.83	1.750	1.280	1.660	1.382	0.469	7/16-14	222	7/16-14X1.75
W35-24	W34-24	1.50	1.50	3.07	3.66	1.406	2.750	1.73	0.98	2.115	1.502	1.900	1.612	0.531	1/2-13	225	1/2-13X1.75
W35-32	W34-32	2.00	2.00	3.54	4.00	1.688	3.062	1.77	0.98	2.490	1.941	2.375	2.069	0.531	1/2-13	228	1/2-13X1.75
W35-40	W34-40	2.50	2.50	4.09	4.49	2.000	3.500	1.97	0.98	2.995	2.325	2.875	2.471	0.531	1/2-13	232	1/2-13X1.75
W35-48	W34-48	3.00	3.00	4.88	5.28	2.438	4.188	1.97	1.06	3.615	2.902	3.500	3.070	0.656	5/8-11	237	5/8-11X2.00
W35-56	W34-56	3.50	3.50	5.35	5.98	2.750	4.750	2.19	1.06	4.095	3.366	4.000	3.550	0.656	5/8-11	241	5/8-11X2.00
W35-64	W34-64	4.00	4.00	5.75	6.38	3.062	5.125	2.19	1.06	4.595	3.828	4.500	4.028	0.656	5/8-11	245	5/8-11X2.75
W35-80*	W34-80*	5.00	5.00	7.00	7.25	3.625	6.000	2.00	1.50	5.595	4.81	5.62	5.078	0.660	5/8-11	253	5/8-11X2.50

Made from bar stock.

CODE 61 BUTT WELD - SCHEDULE 80 PIPE

PART NO. O-RING FIG. 1	PART NO. FLAT FACE FIG. 2	PIPE SIZE	PAD SIZE	A	B	C	D	E	F	G	H	J	L	M UNC-2B	MOUNTING HARDWARE	
															O-RING	SHCS
W24-8	W23-8	0.50	0.50	1.81	2.13	0.688	1.500	1.42	0.63	1.000	0.548	0.840	0.344	5/16-18	210	5/16-18X1.25
W24-12	W23-12	0.75	0.75	1.97	2.56	0.875	1.875	1.42	0.71	1.250	0.744	1.050	0.406	3/8-16	214	3/8-16X1.50
W24-16	W23-16	1.00	1.00	2.17	2.75	1.031	2.062	1.50	0.71	1.560	0.959	1.315	0.406	3/8-16	219	3/8-16X1.50
W24-20	W23-20	1.25	1.25	2.68	3.12	1.188	2.312	1.61	0.83	1.750	1.280	1.660	0.469	7/16-14	222	7/16-14X1.75
W24-24	W23-24	1.50	1.50	3.07	3.66	1.406	2.750	1.73	0.98	2.115	1.502	1.900	0.531	1/2-13	225	1/2-13X1.75
W24-32	W23-32	2.00	2.00	3.54	4.00	1.688	3.062	1.77	0.98	2.490	1.941	2.375	0.531	1/2-13	228	1/2-13X1.75
W24-40	W23-40	2.50	2.50	4.09	4.49	2.000	3.500	1.97	0.98	2.995	2.325	2.875	0.531	1/2-13	232	1/2-13X1.75
W24-48	W23-48	3.00	3.00	4.88	5.28	2.438	4.188	1.97	1.06	3.615	2.902	3.500	0.656	5/8-11	237	5/8-11X2.00

CODE 61 BUTT WELD - SCHEDULE 160 PIPE

PART NO. O-RING FIG. 1	PART NO. FLAT FACE FIG. 2	PIPE SIZE	PAD SIZE	A	B	C	D	E	F	G	H	J	L	M UNC-2B	MOUNTING HARDWARE	
															O-RING	SHCS
W27-8	W25-8	0.50	0.50	1.81	2.13	0.688	1.500	1.42	0.63	1.000	0.466	0.840	0.344	5/16-18	210	5/16-18X1.25
W27-12	W25-12	0.75	0.75	1.97	2.56	0.875	1.875	1.42	0.71	1.250	0.614	1.050	0.406	3/8-16	214	3/8-16X1.50
W27-16	W25-16	1.00	1.00	2.17	2.75	1.031	2.062	1.50	0.71	1.560	0.817	1.315	0.406	3/8-16	219	3/8-16X1.50
W27-20	W25-20	1.25	1.25	2.68	3.12	1.188	2.312	1.61	0.83	1.750	1.162	1.660	0.469	7/16-14	222	7/16-14X1.75
W27-24	W25-24	1.50	1.50	3.07	3.66	1.406	2.750	1.73	0.98	2.115	1.340	1.900	0.531	1/2-13	225	1/2-13X1.75
W27-32	W25-32	2.00	2.00	3.54	4.00	1.688	3.062	1.77	0.98	2.490	1.689	2.375	0.531	1/2-13	228	1/2-13X1.75
W27-40	W25-40	2.50	2.50	4.09	4.49	2.000	3.500	1.97	0.98	2.995	2.127	2.875	0.531	1/2-13	232	1/2-13X1.75
W27-48	W25-48	3.00	3.00	4.88	5.28	2.438	4.188	1.97	1.06	3.615	2.626	3.500	0.656	5/8-11	237	5/8-11X2.00

Trilex Fluid Power • (PHONE) 905-545-2038 • (FAX) 905-545-0528
email: wbisson@trilexfluidpower.com • web: www.trilexfluidpower.com

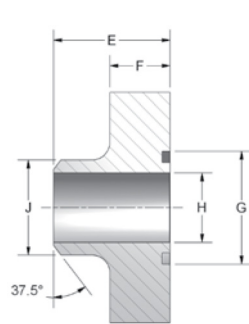
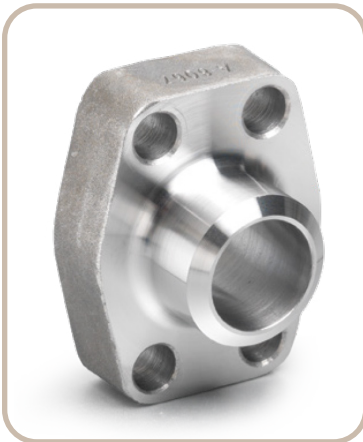

Figure 1

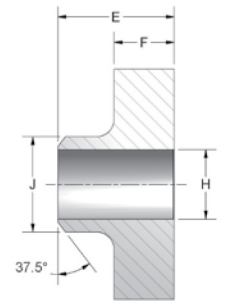
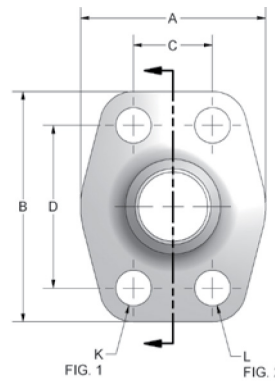

Figure 2

- Mounting kit available on o-ring grooved flanges by simply adding suffix letter 'U' to part number.

CODE 62 BUTT WELD - SCHEDULE 80 PIPE

PART NO. O-RING FIG. 1	PART NO. FLAT FACE FIG. 2	PIPE SIZE	PAD SIZE	A	B	C	D	E	F	G	H	J	K	L UNC-2B	MOUNTING HARDWARE	
															O-RING	SHCS
W28-8	W26-8	0.50	0.50	1.81	2.21	0.718	1.594	1.42	0.63	1.000	0.548	0.840	0.344	5/16-18	210	5/16-18X1.25
W28-12	W26-12	0.75	0.75	2.17	2.80	0.937	2.000	1.38	0.83	1.250	0.744	1.050	0.406	3/8-16	214	3/8-16X1.50
W28-16	W26-16	1.00	1.00	2.56	3.19	1.093	2.250	1.61	0.83	1.560	0.959	1.315	0.492	7/16-14	219	7/16-14X1.75
W28-20	W26-20	1.25	1.25	3.07	3.75	1.250	2.625	1.73	0.98	1.750	1.280	1.660	0.531	1/2-13	222	1/2-13X1.75
W28-24	W26-24	1.50	1.50	3.70	4.41	1.437	3.125	2.17	1.18	2.115	1.502	1.900	0.656	5/8-11	225	5/8-11X2.25
W28-32	W26-32	2.00	2.00	4.50	5.28	1.750	3.812	2.56	1.46	2.490	1.941	2.375	0.781	3/4-10	228	3/4-10X3.00
W28-40	W26-40	2.50	2.50	5.00	6.88	2.311	4.874	2.37	1.50	2.995	2.325	2.875	0.906	7/8-9	232	7/8-9X3.00
W28-48	W26-48	3.00	3.00	6.00	8.50	2.811	6.000	2.96	2.00	3.615	2.902	3.500	1.190	1 1/8-7	237	1 1/8-7X4.00

CODE 62 BUTT WELD - SCHEDULE 160 PIPE

PART NO. O-RING FIG. 1	PART NO. FLAT FACE FIG. 2	PIPE SIZE	PAD SIZE	A	B	C	D	E	F	G	H	J	K	L UNC-2B	MOUNTING HARDWARE	
															O-RING	SHCS
W30-8	W29-8	0.50	0.50	1.81	2.21	0.718	1.594	1.42	0.63	1.000	0.466	0.840	0.344	5/16-18	210	5/16-18X1.25
W30-12	W29-12	0.75	0.75	2.17	2.80	0.937	2.000	1.38	0.83	1.250	0.614	1.050	0.406	3/8-16	214	3/8-16X1.50
W30-16	W29-16	1.00	1.00	2.56	3.19	1.093	2.250	1.61	0.83	1.560	0.817	1.315	0.492	7/16-14	219	7/16-14X1.75
W30-20	W29-20	1.25	1.25	3.07	3.75	1.250	2.625	1.73	0.98	1.750	1.162	1.660	0.531	1/2-13	222	1/2-13X1.75
W30-24	W29-24	1.50	1.50	3.70	4.41	1.437	3.125	2.17	1.18	2.115	1.340	1.900	0.656	5/8-11	225	5/8-11X2.25
W30-32	W29-32	2.00	2.00	4.50	5.28	1.750	3.812	2.56	1.46	2.490	1.689	2.375	0.781	3/4-10	228	3/4-10X3.00
W30-40	W29-40	2.50	2.50	5.00	6.88	2.311	4.874	2.37	1.50	2.995	2.127	2.875	0.906	7/8-9	232	7/8-9X3.00
W30-48	W29-48	3.00	3.00	6.00	8.50	2.811	6.000	2.96	2.00	3.615	2.626	3.500	1.190	1 1/8-7	237	1 1/8-7X4.00

CODE 62 BUTT WELD - SCHEDULE XXS PIPE

PART NO. O-RING FIG. 1	PART NO. FLAT FACE FIG. 2	PIPE SIZE	PAD SIZE	A	B	C	D	E	F	G	H	J	K	L UNC-2B	MOUNTING HARDWARE	
															O-RING	SHCS
W33-8	W32-8	0.50	0.50	1.81	2.21	0.718	1.594	1.42	0.63	1.000	0.254	0.840	0.344	5/16-18	210	5/16-18X1.25
W33-12	W32-12	0.75	0.75	2.17	2.80	0.937	2.000	1.38	0.83	1.250	0.436	1.050	0.406	3/8-16	214	3/8-16X1.50
W33-16	W32-16	1.00	1.00	2.56	3.19	1.093	2.250	1.61	0.83	1.560	0.601	1.315	0.492	7/16-14	219	7/16-14X1.75
W33-20	W32-20	1.25	1.25	3.07	3.75	1.250	2.625	1.73	0.98	1.750	0.898	1.660	0.531	1/2-13	222	1/2-13X1.75
W33-24	W32-24	1.50	1.50	3.70	4.41	1.437	3.125	2.17	1.18	2.115	1.102	1.900	0.656	5/8-11	225	5/8-11X2.25
W33-32	W32-32	2.00	2.00	4.50	5.28	1.750	3.812	2.56	1.46	2.490	1.505	2.375	0.781	3/4-10	228	3/4-10X3.00
W33-40	W32-40	2.50	2.50	5.00	6.88	2.311	4.874	2.37	1.50	2.995	1.773	2.875	0.906	7/8-9	232	7/8-9X3.00
W33-48	W32-48	3.00	3.00	6.00	8.50	2.811	6.000	2.96	2.00	3.615	2.302	3.500	1.190	1 1/8-7	237	1 1/8-7X4.00

SADDLE WELD

FLANGES -
CARBON STEEL

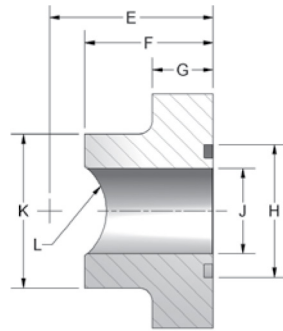
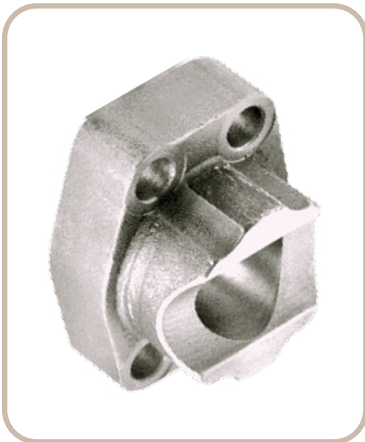

Figure 1

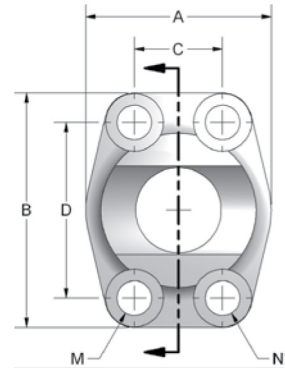

FIG. 1

FIG. 2

*No Spotface

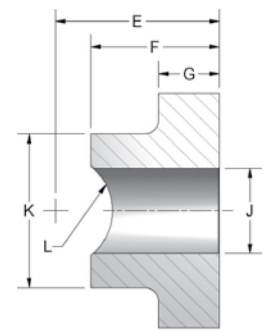

Figure 2

- Mounting kit available on o-ring grooved flanges by simply adding suffix letter 'U' to part number.

CODE 61 SADDLE WELD - PIPE

PART NO. O-RING FIG. 1	PART NO. FLAT FACE FIG. 2	PIPE SIZE	PAD SIZE	A	B	C	D	E	F	G	H	J	K	L	M	N UNC-2B	MOUNTING HARDWARE	
																	O-RING	SHCS
W8-12-12	W7-12-12	0.75	0.75	1.97	2.56	0.875	1.875	1.775	1.42	0.71	1.250	0.752	1.54	0.532	0.406	3/8-16	214	3/8-16X1.50
W8-16-16	W7-16-16	1.00	1.00	2.17	2.75	1.031	2.062	1.912	1.50	0.71	1.560	1.002	1.81	0.665	0.406	3/8-16	219	3/8-16X1.50
W8-20-20	W7-20-20	1.25	1.25	2.68	3.12	1.188	2.312	2.146	1.61	0.83	1.750	1.252	2.22	0.837	0.469	7/16-14	222	7/16-14X1.75
W8-24-24	W7-24-24	1.50	1.50	3.07	3.66	1.406	2.750	2.290	1.77	0.98	2.115	1.502	2.50	0.957	0.531	1/2-13	225	1/2-13X1.75
W8-32-32	W7-32-32	2.00	2.00	3.54	4.00	1.688	3.062	2.340	1.77	0.98	2.490	2.002	3.12	1.200	0.531	1/2-13	228	1/2-13X1.75
W8-40-40	W7-40-40	2.50	2.50	4.09	4.49	2.000	3.500	2.660	1.97	0.98	2.995	2.502	3.62	1.451	0.531	1/2-13	232	1/2-13X1.75

CODE 61 SADDLE WELD - TUBE

PART NO. O-RING FIG. 1	PART NO. FLAT FACE FIG. 2	PIPE SIZE	PAD SIZE	A	B	C	D	E	F	G	H	J	K	L	M	N UNC-2B	MOUNTING HARDWARE	
																	O-RING	SHCS
W87-12-12	W69-12-12	0.75	0.75	1.97	2.56	0.875	1.875	1.420	1.41	0.71	1.250	0.614	1.05	0.382	0.406	3/8-16	214	3/8-16X1.50
W87-16-12	W69-16-12	1.00	0.75	1.97	2.56	0.875	1.875	1.737	1.42	0.71	1.250	0.752	1.54	0.507	0.406	3/8-16	214	3/8-16X1.50
W87-16-16	W69-16-16	1.00	1.00	2.17	2.75	1.031	2.062	1.500	1.47	0.71	1.560	0.817	1.32	0.507	0.406	3/8-16	219	3/8-16X1.50
W87-20-16	W69-20-16	1.25	1.00	2.17	2.75	1.031	2.062	1.858	1.50	0.71	1.560	1.002	1.81	0.632	0.406	3/8-16	219	3/8-16X1.50
W87-20-20	W69-20-20	1.25	1.25	2.68	3.12	1.188	2.312	1.665	1.61	0.83	1.750	1.162	1.66	0.632	0.469	7/16-14	222	7/16-14X1.75
W87-24-20	W69-24-20	1.50	1.25	2.68	3.12	1.188	2.312	2.022	1.61	0.83	1.750	1.252	2.22	0.757	0.469	7/16-14	222	7/16-14X1.75
W87-28-24	W69-28-24	1.75	1.50	3.07	3.66	1.406	2.750	2.198	1.77	0.98	2.115	1.502	2.50	0.882	0.531	1/2-13	225	1/2-13X1.75
W87-32-32	W69-32-32	2.00	2.00	3.54	4.00	1.688	3.062	2.262	1.77	0.98	2.490	1.689	2.38	1.007	0.531	1/2-13	228	1/2-13X1.75
W87-36-32	W69-36-32	2.25	2.00	3.54	4.00	1.688	3.062	2.247	1.77	0.98	2.490	2.002	3.12	1.132	0.531	1/2-13	228	1/2-13X1.75

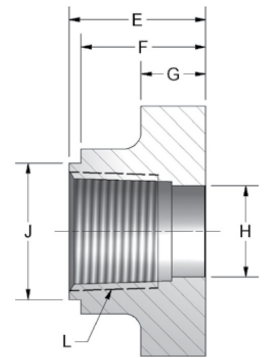
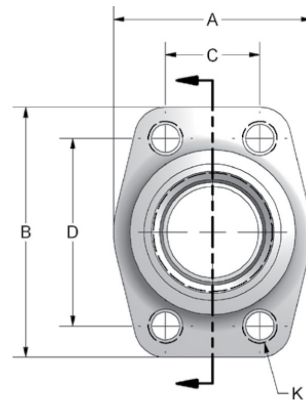

- Female NPTF thread added to facilitate pump suction line and return line applications.

CODE 61 NPTF TANK PILOT

PART NO.	PIPE SIZE	PAD SIZE	A	B	C	D	E	F	G	H	J	K UNC-2B	L NPTF
W22-12	0.750	0.750	1.97	2.56	0.875	1.875	1.42	1.30	0.71	0.752	1.375	3/8-16	3/4-14
W22-16	1.00	1.00	2.17	2.75	1.031	2.062	1.50	1.37	0.71	1.002	1.500	3/8-16	1-11.5
W22-20	1.25	1.25	2.68	3.12	1.188	2.312	1.61	1.49	0.83	1.252	1.750	7/16-14	1 1/4-11.5
W22-24	1.50	1.50	3.07	3.66	1.406	2.750	1.77	1.64	0.98	1.502	2.125	1/2-13	1 1/2-11.5
W22-32	2.00	2.00	3.54	4.00	1.688	3.062	1.77	1.65	0.98	2.002	2.500	1/2-13	2-11.5
W22-40	2.50	2.50	4.09	4.49	2.000	3.500	1.97	1.85	0.98	2.502	3.250	1/2-13	2 1/2-8
W22-48	3.00	3.00	4.88	5.28	2.438	4.188	1.97	1.85	1.06	3.002	3.625	5/8-11	3-8
W22-56	3.50	3.50	5.35	5.98	2.750	4.750	1.89	1.77	1.06	3.504	4.125	5/8-11	3 1/2-8
W22-64	4.00	4.00	5.75	6.38	3.062	5.125	1.89	1.77	1.06	3.898	4.625	5/8-11	4-8

ELBOW BLOCK

FLANGES -
CARBON STEEL

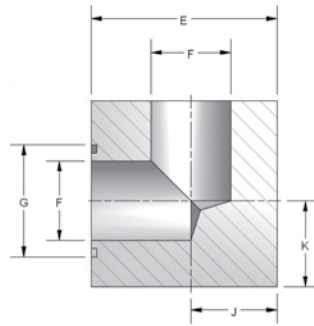

Figure 1

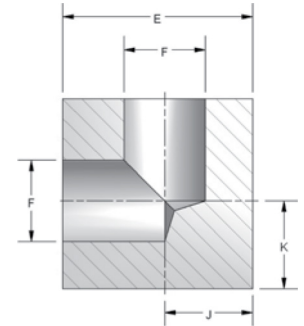
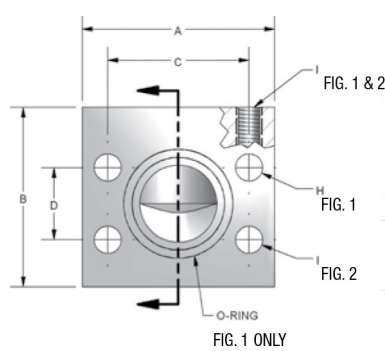

Figure 2

- Mounting kit available on o-ring grooved flanges by simply adding suffix letter 'U' to part number.

CODE 61 ELBOW BLOCK

PART NO. O-RING FIG. 1	PART NO. FLAT FACE FIG. 2	PAD SIZE	A	B	C	D	E	F	G	H	I UNC-2B	J	K	MOUNTING HARDWARE	
														O-RING	SHCS
W14-12	W15-12	0.75	2.62	2.47	1.875	0.875	2.25	0.75	1.250	0.406	3/8-16	1.03	1.03	214	3/8-16X3.00
W14-16	W15-16	1.00	2.82	2.47	2.062	1.031	2.47	1.00	1.560	0.406	3/8-16	1.16	1.09	219	3/8-16X3.25
W14-20	W15-20	1.25	3.19	2.97	2.312	1.188	2.97	1.25	1.750	0.469	7/16-14	1.44	1.31	222	7/16-14X4.00
W14-24	W15-24	1.50	3.75	3.47	2.750	1.406	3.47	1.50	2.115	0.531	1/2-13	1.62	1.62	225	1/2-13X4.50
W14-32	W15-32	2.00	4.00	3.97	3.062	1.688	3.97	2.00	2.490	0.531	1/2-13	1.91	1.91	228	1/2-13X5.00

CODE 62 ELBOW BLOCK

PART NO. O-RING FIG. 1	PART NO. FLAT FACE FIG. 2	PAD SIZE	A	B	C	D	E	F	G	H	I UNC-2B	J	K	MOUNTING HARDWARE	
														O-RING	SHCS
W12-12	W13-12	0.75	2.82	2.47	2.000	0.937	2.47	0.750	1.250	0.406	3/8-16	1.19	1.06	214	3/8-16X3.50
W12-16	W13-16	1.00	3.19	2.97	2.250	1.093	2.97	1.00	1.560	0.469	7/16-14	1.38	1.38	219	7/16-14X4.00
W12-20	W13-20	1.25	3.75	3.47	2.625	1.250	3.47	1.25	1.750	0.531	1/2-13	1.62	1.41	222	1/2-13X4.50
W12-24	W13-24	1.50	4.50	3.97	3.125	1.437	3.97	1.50	2.115	0.656	5/8-11	1.88	1.75	225	5/8-11X5.00
W12-32	W13-32	2.00	5.25	4.97	3.812	1.75	4.97	2.00	2.490	0.781	3/4-10	2.25	2.50	228	3/4-10X6.00

TEE JUNCTION BLOCK

**FLANGES -
CARBON STEEL**

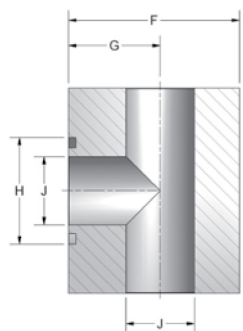

Figure 1

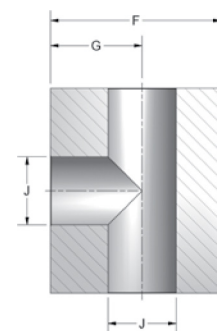
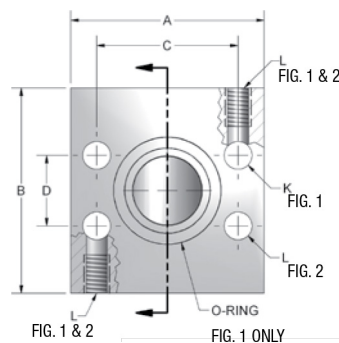

Figure 2

- Mounting kit available on o-ring grooved flanges by simply adding suffix letter 'U' to part number.

CODE 61 TEE JUNCTION BLOCK

PART NO. O-RING FIG. 1	PART NO. FLAT FACE FIG. 2	PAD SIZE	A	B	C	D	F	G	H	J	K	L UNC-2B	MOUNTING HARDWARE	
													O-RING	SHCS
W17-12	W16-12	0.75	2.62	2.75	1.875	0.875	2.25	1.22	1.250	0.75	0.406	3/8-16	214	3/8-16X3.00
W17-16	W16-16	1.00	2.82	2.97	2.062	1.031	2.50	1.34	1.560	1.00	0.406	3/8-16	219	3/8-16X3.25
W17-20	W16-20	1.25	3.19	3.47	2.312	1.188	3.00	1.56	1.750	1.25	0.469	7/16-14	222	7/16-14X4.00
W17-24	W16-24	1.50	3.75	3.97	2.750	1.406	3.50	1.88	2.115	1.50	0.531	1/2-13	225	1/2-13X4.50
W17-32	W16-32	2.00	4.00	4.25	3.062	1.688	3.97	2.09	2.490	2.00	0.531	1/2-13	228	1/2-13X5.00

CODE 62 TEE JUNCTION BLOCK

PART NO. O-RING FIG. 1	PART NO. FLAT FACE FIG. 2	PAD SIZE	A	B	C	D	F	G	H	J	K	L UNC-2B	MOUNTING HARDWARE	
													O-RING	SHCS
W19-12	W18-12	0.75	2.81	2.97	2.00	0.937	2.50	1.310	1.250	0.750	0.406	3/8-16	214	3/8-16X3.25
W19-16	W18-16	1.00	3.19	3.47	2.25	1.093	3.00	1.620	1.560	1.000	0.492	7/16-14	219	7/16-14X4.00
W19-20	W18-20	1.25	3.75	3.97	2.625	1.250	3.50	1.880	1.750	1.250	0.531	1/2-13	222	1/2-13X4.50
W19-24	W18-24	1.50	4.50	4.47	3.125	1.437	4.00	2.120	2.115	1.500	0.656	5/8-11	225	5/8-11X5.00
W19-32	W18-32	2.00	5.25	4.97	3.812	1.750	4.97	2.750	2.490	1.940	0.781	3/4-10	228	3/4-10X6.00

THREADED ELBOW

FLANGES -
CARBON STEEL

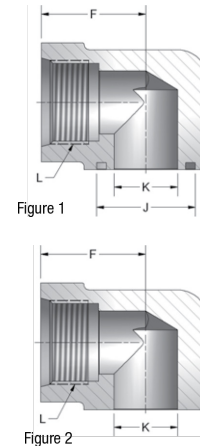
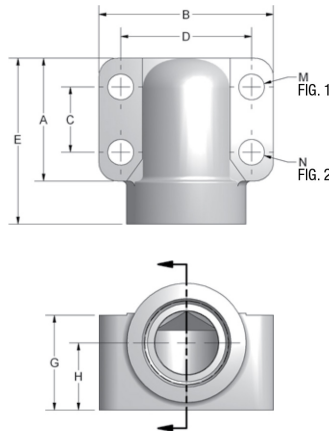

- Mounting kit available on o-ring grooved flanges by simply adding suffix letter 'U' to part number.

CODE 61 ELBOW SAE STRAIGHT THREAD

PART NO. O-RING FIG. 1	PART NO. FLAT FACE FIG. 2	PAD SIZE	A	B	C	D	E	F	G	H	J	K	L	M	N UNC-2B	MOUNTING HARDWARE	
																O-RING	SHCS
W164-12-12	W165-12-12	0.75	1.69	2.56	0.875	1.875	2.28	1.44	1.25	0.875	1.250	0.752	1-1/16-12	0.406	3/8-16	214	3/8-16X2.00
W164-16-16	W165-16-16	1.00	1.94	2.75	1.031	2.062	2.62	1.66	1.50	1.062	1.560	1.002	1-5/16-12	0.406	3/8-16	219	3/8-16X2.25
W164-20-20	W165-20-20	1.25	2.19	3.12	1.188	2.312	3.00	1.91	1.81	1.188	1.750	1.252	1-5/8-12	0.469	7/16-14	222	7/16-14X2.75
W164-24-24	W165-24-24	1.50	2.56	3.69	1.406	2.750	3.33	2.05	2.00	1.312	2.115	1.502	1-7/8-12	0.531	1/2-13	225	1/2-13X3.00
W164-32-32	W165-32-32	2.00	3.06	4.33	1.688	3.062	3.81	2.28	2.50	1.656	1.490	2.002	2-1/2-12	0.531	1/2-13	228	1/2-13X3.50

CODE 61 ELBOW NPTF THREAD

PART NO. O-RING FIG. 1	PART NO. FLAT FACE FIG. 2	PAD SIZE	A	B	C	D	E	F	G	H	J	K	L	M	N UNC-2B	MOUNTING HARDWARE	
																O-RING	SHCS
W168-12-12	W170-12-12	0.75	1.69	2.56	0.875	1.875	2.28	1.44	1.25	0.875	1.250	0.752	0.75	0.406	3/8-16	214	3/8-16X2.00
W168-16-16	W170-16-16	1.00	1.94	2.75	1.031	2.062	2.62	1.66	1.50	1.062	1.560	1.002	1.00	0.406	3/8-16	219	3/8-16X2.25
W168-20-20	W170-20-20	1.25	2.19	3.12	1.188	2.312	3.00	1.91	1.81	1.188	1.750	1.252	1.25	0.469	7/16-14	222	7/16-14X2.75
W168-24-24	W170-24-24	1.50	2.56	3.69	1.406	2.750	3.33	2.05	2.00	1.312	2.115	1.502	1.50	0.531	1/2-13	225	1/2-13X3.00
W168-32-32	W170-32-32	2.00	3.06	4.33	1.688	3.062	3.81	2.28	2.50	1.656	2.490	2.002	2.00	0.531	1/2-13	228	1/2-13X3.50

CODE 62 ELBOW SAE STRAIGHT THREAD

PART NO. O-RING FIG. 1	PART NO. FLAT FACE FIG. 2	PAD SIZE	A	B	C	D	E	F	G	H	J	K	L	M	N UNC-2B	MOUNTING HARDWARE	
																O-RING	SHCS
W184-12-12	W185-12-12	0.75	1.94	2.75	0.937	2.000	2.62	1.66	1.50	1.062	1.250	0.752	1-1/16-12	0.406	3/8-16	214	3/8-16X2.25
W184-16-16	W185-16-16	1.00	2.19	3.12	1.093	2.250	3.00	1.91	1.81	1.188	1.560	1.002	1-5/16-12	0.492	7/16-14	219	7/16-14X2.50
W184-20-20	W185-20-20	1.25	2.56	3.69	1.250	2.625	3.32	2.05	2.00	1.312	1.750	1.252	1-5/8-12	0.531	1/2-13	222	1/2-13X3.00
W184-24-24	W185-24-24	1.50	3.06	4.33	1.437	3.125	3.81	2.28	2.50	1.656	2.115	1.502	1-7/8-12	0.656	5/8-11	225	5/8-11X3.50

CODE 62 ELBOW NPTF THREAD

PART NO. O-RING FIG. 1	PART NO. FLAT FACE FIG. 2	PAD SIZE	A	B	C	D	E	F	G	H	J	K	L	M	N UNC-2B	MOUNTING HARDWARE	
																O-RING	SHCS
W188-12-12	W180-12-12	0.75	1.94	2.75	0.937	2.000	2.62	1.66	1.50	1.062	1.250	0.752	0.75	0.406	3/8-16	214	3/8-16X2.25
W188-16-16	W180-16-16	1.00	2.19	3.12	1.093	2.250	3.00	1.91	1.81	1.188	1.560	1.002	1.00	0.492	7/16-14	219	7/16-14X2.50
W188-20-20	W180-20-20	1.25	2.56	3.69	1.250	2.625	3.32	2.05	2.00	1.312	1.750	1.252	1.25	0.531	1/2-13	222	1/2-13X3.00
W188-24-24	W180-24-24	1.50	3.06	4.33	1.437	3.125	3.81	2.28	2.50	1.656	2.115	1.502	1.50	0.656	5/8-11	225	5/8-11X3.50

SOCKET WELD PIPE ELBOW

FLANGES -
CARBON STEEL

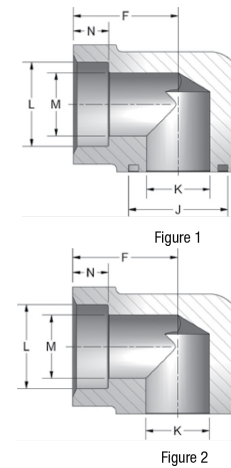
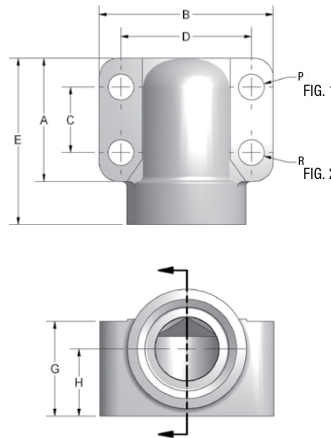

- Mounting kit available on o-ring grooved flanges by simply adding suffix letter 'U' to part number.

CODE 61 ELBOW SOCKET WELD - PIPE

PART NO. O-RING FIG. 1	PART NO. FLAT FACE FIG. 2	PAD SIZE	A	B	C	D	E	F	G	H	J	K	L	M	N	P	R UNC-2B	MOUNTING HARDWARE	
																		O-RING	SHCS
W176-12-12	W169-12-12	0.75	1.69	2.56	0.875	1.875	2.28	1.44	1.25	0.875	1.250	0.752	1.062	0.75	0.56	0.406	3/8-16	214	3/8-16X2.00
W176-16-16	W169-16-16	1.00	1.94	2.75	1.031	2.062	2.62	1.66	1.50	1.062	1.560	1.002	1.328	1.00	0.56	0.406	3/8-16	219	3/8-16X2.25
W176-20-20	W169-20-20	1.25	2.19	3.12	1.188	2.312	3.00	1.91	1.81	1.188	1.750	1.252	1.672	1.25	0.62	0.469	7/16-14	222	7/16-14X2.75
W176-24-24	W169-24-24	1.50	2.56	3.69	1.406	2.750	3.33	2.05	2.00	1.312	2.115	1.502	1.922	1.50	0.69	0.531	1/2-13	225	1/2-13X3.00
W176-32-32	W169-32-32	2.00	3.06	4.33	1.688	3.062	3.81	2.28	2.50	1.656	2.490	2.002	2.406	2.00	0.75	0.531	1/2-13	228	1/2-13X3.50
W176-40-40	W169-40-40	2.50	3.56	5.00	2.000	3.500	4.66	2.88	2.78	1.900	2.995	2.502	2.906	2.50	0.75	0.531	1/2-13	232	1/2-13X5.00
W176-48-48	W169-48-48	3.00	4.00	5.50	2.438	4.188	5.00	3.00	3.35	2.400	3.615	3.002	3.547	3.00	0.75	0.656	5/8-11	237	5/8-11X6.00

CODE 62 ELBOW SOCKET WELD - PIPE

PART NO. O-RING FIG. 1	PART NO. FLAT FACE FIG. 2	PAD SIZE	A	B	C	D	E	F	G	H	J	K	L	M	N	P	R UNC-2B	MOUNTING HARDWARE	
																		O-RING	SHCS
W186-12-12	W189-12-12	0.75	1.94	2.75	0.937	2.000	2.62	1.66	1.50	1.062	1.250	0.752	1.062	0.75	0.56	0.406	3/8-16	214	3/8-16X2.25
W186-16-16	W189-16-16	1.00	2.19	3.12	1.093	2.250	3.00	1.91	1.81	1.188	1.560	1.002	1.328	1.00	0.62	0.492	7/16-14	219	7/16-14X2.50
W186-20-20	W189-20-20	1.25	2.56	3.69	1.250	2.625	3.32	2.05	2.00	1.312	1.750	1.252	1.672	1.25	0.69	0.531	1/2-13	222	1/2-13X3.00
W186-24-24	W189-24-24	1.50	3.06	4.33	1.437	3.125	3.81	2.28	2.50	1.656	2.115	1.502	1.922	1.50	0.75	0.656	5/8-11	225	5/8-11X3.50
W186-32-32	W189-32-32	2.00	3.56	5.00	1.750	3.812	4.66	2.88	2.69	1.900	2.490	2.002	2.406	2.00	0.75	0.781	3/4-10	228	3/4-10X4.50

SOCKET WELD TUBE ELBOW

FLANGES -
CARBON STEEL

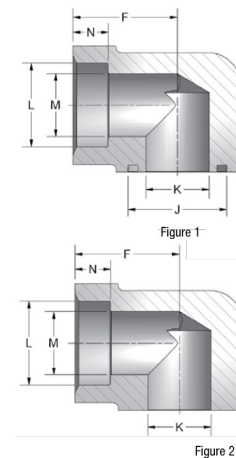
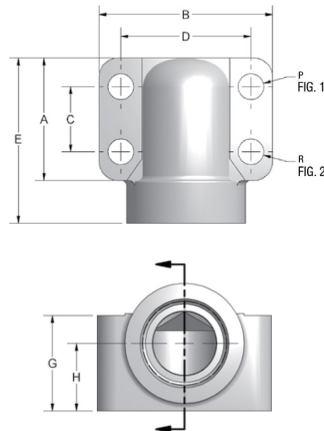

- Mounting kit available on o-ring grooved flanges by simply adding suffix letter 'U' to part number.

CODE 61 ELBOW SOCKET WELD - TUBE

PART NO. O-RING FIG. 1	PART NO. FLAT FACE FIG. 2	PAD SIZE	A	B	C	D	E	F	G	H	J	K	L	M	N	P	R UNC-2B	MOUNTING HARDWARE	
																		O-RING	SHCS
W172-12-12	W177-12-12	0.75	1.69	2.56	0.875	1.875	2.28	1.44	1.25	0.875	1.250	0.752	0.752	0.625	0.312	0.406	3/8-16	214	3/8-16X2.00
W172-16-12	W177-16-12	0.75	1.69	2.56	0.875	1.875	2.28	1.44	1.25	0.875	1.250	0.752	1.002	0.750	0.438	0.406	3/8-16	214	3/8-16X2.00
W172-16-16	W177-16-16	1.00	1.94	2.75	1.031	2.062	2.62	1.66	1.50	1.062	1.560	1.002	1.002	0.875	0.438	0.406	3/8-16	219	3/8-16X2.25
W172-20-16	W177-20-16	1.00	1.94	2.75	1.031	2.062	2.62	1.66	1.50	1.062	1.560	1.002	1.252	1.000	0.500	0.406	3/8-16	219	3/8-16X2.25
W172-20-20	W177-20-20	1.25	2.19	3.12	1.188	2.312	3.00	1.91	1.81	1.188	1.750	1.252	1.252	1.125	0.500	0.469	7/16-14	222	7/16-14X2.75
W172-24-20	W177-24-20	1.25	2.19	3.12	1.188	2.312	3.00	1.91	1.81	1.188	1.750	1.252	1.502	1.250	0.562	0.469	7/16-14	222	7/16-14X2.75
W172-24-24	W177-24-24	1.50	2.56	3.69	1.406	2.750	3.33	2.05	2.00	1.312	2.115	1.502	1.502	1.375	0.562	0.531	1/2-13	225	1/2-13X3.00
W172-28-24	W177-28-24	1.50	2.56	3.69	1.406	2.750	3.33	2.05	2.00	1.312	2.115	1.502	1.752	1.500	0.562	0.531	1/2-13	225	1/2-13X3.00
W172-32-32	W177-32-32	2.00	3.06	4.33	1.688	3.062	3.81	2.28	2.50	1.656	2.490	2.002	2.002	1.875	0.625	0.531	1/2-13	228	1/2-13X3.50
W172-36-32	W177-36-32	2.00	3.06	4.33	1.688	3.062	3.81	2.28	2.50	1.656	2.490	2.002	2.252	2.000	0.625	0.531	1/2-13	228	1/2-13X3.50

CODE 62 ELBOW SOCKET WELD - TUBE

PART NO. O-RING FIG. 1	PART NO. FLAT FACE FIG. 2	PAD SIZE	A	B	C	D	E	F	G	H	J	K	L	M	N	P	R UNC-2B	MOUNTING HARDWARE	
																		O-RING	SHCS
W182-12-12	W187-12-12	0.75	1.94	2.75	0.937	2.000	2.62	1.66	1.50	1.062	1.250	0.752	0.752	0.625	0.56	0.406	3/8-16	214	3/8-16X2.25
W182-16-12	W187-16-12	0.75	1.94	2.75	0.937	2.000	2.62	1.66	1.50	1.062	1.250	0.752	1.002	0.750	0.62	0.406	3/8-16	214	3/8-16X2.25
W182-16-16	W187-16-16	1.00	2.19	3.12	1.093	2.250	3.00	1.91	1.81	1.188	1.560	1.002	1.002	0.875	0.62	0.492	7/16-14	219	7/16-14X2.50
W182-20-16	W187-20-16	1.00	2.19	3.12	1.093	2.250	3.00	1.91	1.81	1.188	1.560	1.002	1.252	1.000	0.69	0.492	7/16-14	219	7/16-14X2.50
W182-20-20	W187-20-20	1.25	2.56	3.69	1.250	2.625	3.32	2.05	2.00	1.312	1.750	1.252	1.252	1.125	0.69	0.531	1/2-13	222	1/2-13X3.00
W182-24-20	W187-24-20	1.25	2.56	3.69	1.250	2.625	3.32	2.05	2.00	1.312	1.750	1.252	1.502	1.250	0.75	0.531	1/2-13	222	1/2-13X3.00
W182-24-24	W187-24-24	1.50	3.06	4.33	1.437	3.125	3.81	2.28	2.50	1.656	2.115	1.502	1.502	1.375	0.75	0.656	5/8-11	225	5/8-11X3.50
W182-28-24	W187-28-24	1.50	3.06	4.33	1.437	3.125	3.81	2.28	2.50	1.656	2.115	1.502	1.752	1.500	0.75	0.656	5/8-11	225	5/8-11X3.50

3000 SERIES SQUARE PATTERN

FLANGES -
CARBON STEEL

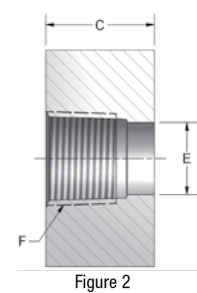
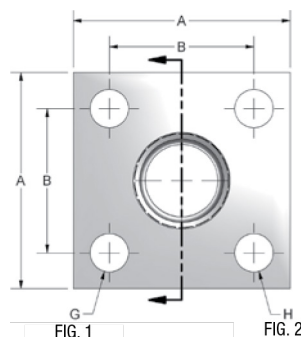
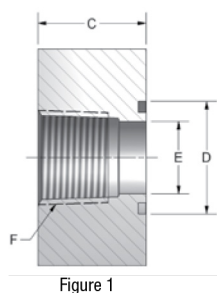

- Mounting kit available on o-ring grooved flanges by simply adding suffix letter 'U' to part number.

3000 SERIES SQUARE NPTF THREAD

PART NO. O-RING FIG. 1	PART NO. FLAT FACE FIG. 2	PAD SIZE	A	B	C	D	E	F	G	H UNC-2B	MOUNTING HARDWARE	
											O-RING	SHCS
W65-12	W75-12	0.75	2.25	1.438	1.25	1.250	0.752	0.75	0.406	3/8-16	214	3/8-16X2.00
W65-16	W75-16	1.00	3.00	2.000	1.50	1.560	1.002	1.00	0.531	1/2-13	219	1/2-13X2.25
W65-20	W75-20	1.25	3.00	2.000	1.50	1.750	1.252	1.25	0.531	1/2-13	222	1/2-13X2.25
W65-24	W75-24	1.50	4.00	2.750	1.75	2.115	1.502	1.50	0.656	5/8-11	225	5/8-11X2.75
W65-32	W75-32	2.00	4.00	2.750	1.75	2.490	2.002	2.00	0.656	5/8-11	228	5/8-11X2.75
W65-40	W75-40*	2.50	5.50	3.750	2.25	2.995	2.502	2.50	0.906	7/8-9	232	7/8-9X3.50*
W65-48	W75-48*	3.00	5.50	3.750	2.25	3.615	3.002	3.00	0.906	7/8-9	237	7/8-9X3.50*

*HHCS provided on 7/8" size bolts and larger.

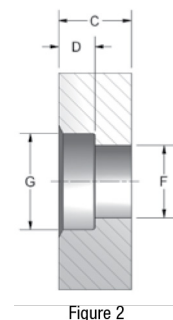
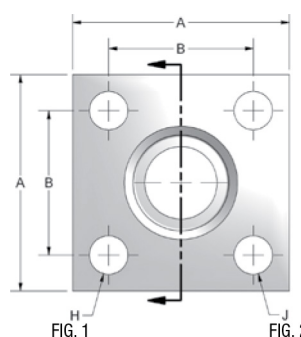
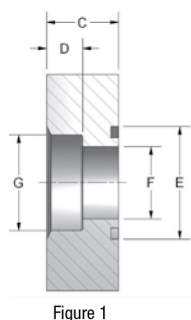

- Mounting kit available on o-ring grooved flanges by simply adding suffix letter 'U' to part number.

3000 SERIES SQUARE SOCKET WELD - PIPE

PART NO. O-RING FIG. 1	PART NO. FLAT FACE FIG. 2	PAD SIZE	A	B	C	D	E	F	G	H	J UNC-2B	MOUNTING HARDWARE	
												O-RING	SHCS
W66-12	W76-12	0.75	2.25	1.438	1.00	0.50	1.250	0.752	1.062	0.406	3/8-16	214	3/8-16X1.75
W66-16	W76-16	1.00	3.00	2.000	1.00	0.50	1.560	1.002	1.328	0.531	1/2-13	219	1/2-13X1.75
W66-20	W76-20	1.25	3.00	2.000	1.00	0.50	1.750	1.252	1.672	0.531	1/2-13	222	1/2-13X1.75
W66-24	W76-24	1.50	4.00	2.750	1.25	0.62	2.115	1.502	1.922	0.656	5/8-11	225	5/8-11X2.25
W66-32	W76-32	2.00	4.00	2.750	1.25	0.62	2.490	2.002	2.406	0.656	5/8-11	228	5/8-11X2.25
W66-40	W76-40*	2.50	5.50	3.750	1.50	0.75	2.995	2.502	2.906	0.906	7/8-9	232	7/8-9X2.75*
W66-48	W76-48*	3.00	5.50	3.750	1.50	0.75	3.615	3.002	3.547	0.906	7/8-9	237	7/8-9X2.75*
W66-64	W76-64*	4.00	7.00	5.000	2.00	0.75	4.625	3.880	4.578	1.060	1-8	347	1-8X3.50*

*HHCS provided on 7/8" size bolts and larger.

Trilex Fluid Power • (PHONE) 905-545-2038 • (FAX) 905-545-0528
email: wbisson@trilexfluidpower.com • web: www.trilexfluidpower.com

6000 SERIES SQUARE PATTERN

FLANGES -
CARBON STEEL

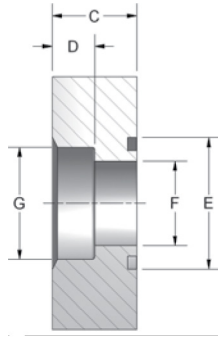

Figure 1

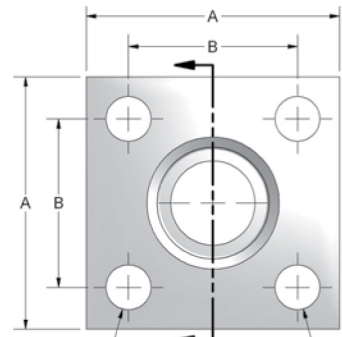

FIG. 1

FIG. 2

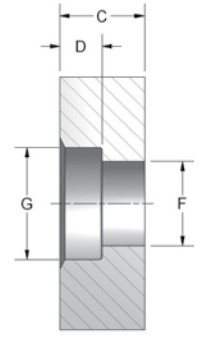
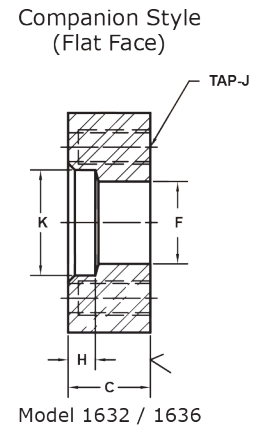
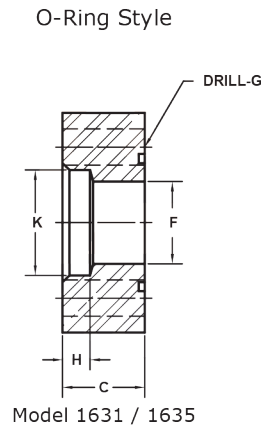
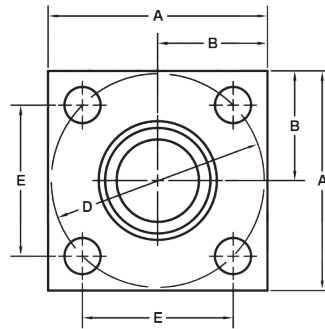
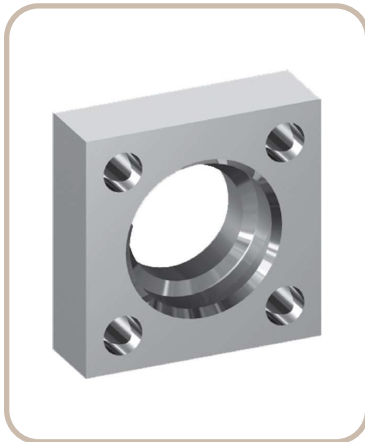

Figure 2

- Mounting kit available on o-ring grooved flanges by simply adding suffix letter 'U' to part number.

6000 SERIES SQUARE SOCKET WELD - PIPE

PART NO. O-RING FIG. 1	PART NO. FLAT FACE FIG. 2	PIPE SIZE	A	B	C	D	E	F	G	H	J UNC-2B	MOUNTING HARDWARE	
												O-RING	HHCS
W56-40	W57-40	2.50	5.50	3.750	1.75	0.75	2.995	2.12	2.911	0.94	7/8-9	232	7/8-9X3.50
W56-48	W57-48	3.00	6.75	4.750	2.00	0.75	3.615	2.62	3.540	1.06	1-8	236	1-8X4.00
W56-56	W57-56	3.50	8.00	5.500	2.40	1.002	3.990	3.00	4.045	1.31	1 1/4-7	342	1 1/4X5.00
W56-64	W57-64	4.00	8.50	6.000	2.40	1.002	4.490	3.44	4.550	1.31	1 1/4-7	346	1 1/4X5.00
W56-80	W57-80	5.00	10.00	7.250	2.90	1.002	5.365	4.31	5.625	1.56	1 1/2-6	353	1 1/2X6.00



ISO 6164 BOLT PATTERN - 250 BAR SERIES

FLANGE SIZE	PIPE SIZE	PART #	A	B	C	D (mm)	E	F	G (mm)		H	K	MOUNTING HARDWARE			WEIGHT																																																																																															
									J (mm)				PART #	SCREW SIZE	O-RING																																																																																																
10	3/8"	1631-06-06M	4.00	2.00	1.60	98	2.728	1.94	17.5	0.62	2.411	MKM 3531	M16 X 65	228	4.9																																																																																																
		J (mm)																																																																																																													
13	1/2"	1632-06-06M							4.75							2.38	1.88	118	3.285	2.44	22.0	0.75	2.911	MKM 5573	M20 X 80	232	7.8																																																																																				
		J (mm)																																																																																																													
19	3/4"	1631-08-08M																			5.50							2.75	2.28	145	4.037	2.94	22.0	0.75	3.540	MKM 5558	M20 X 90	237	12.8																																																																								
		J (mm)																																																																																																													
25	1"	1632-08-08M																															4.00							2.00	1.60	98	2.728	1.94	17.5	0.62	2.411	MKM 3531	M16 X 65	228	4.9																																																												
		J (mm)																																																																																																													
32	1-1/4"	1631-12-12M																																											4.75							2.38	1.88	118	3.285	2.44	22.0	0.75	2.911	MKM 5573	M20 X 80	232	7.8																																																
		J (mm)																																																																																																													
38	1-1/2"	1632-12-12M																																																							5.50							2.75	2.28	145	4.037	2.94	22.0	0.75	3.540	MKM 5558	M20 X 90	237	12.8																																				
		J (mm)																																																																																																													
51	2"	1631-16-16M																																																																			4.00							2.00	1.60	98	2.728	1.94	17.5	0.62	2.411	MKM 3531	M16 X 65	228	4.9																								
		J (mm)																																																																																																													
56	2-1/2"	1632-16-16M																																																																															4.75							2.38	1.88	118	3.285	2.44	22.0	0.75	2.911	MKM 5573	M20 X 80	232	7.8												
		J (mm)																																																																																																													
63	3"	1631-20-20M																																																																																											5.50							2.75	2.28	145	4.037	2.94	22.0	0.75	3.540	MKM 5558	M20 X 90	237	12.8
		J (mm)																																																																																																													

PLEASE USE THE 400 BAR SERIES FOUND BELOW. THE BLOCK SIZE, BOLT PATTERN AND THE O-RING ARE IDENTICAL IN FLANGE SIZES 10-38.

ISO 6164 BOLT PATTERN - 400 BAR SERIES

FLANGE SIZE	PIPE SIZE	PART #	A	B	C	D (mm)	E	F	G (mm)		H	K	MOUNTING HARDWARE			WEIGHT																																																																																																											
									J (mm)				PART #	SCREW SIZE	O-RING																																																																																																												
10	3/8"	1635-06-06M	1.50	0.75	0.73	35	0.974	0.44	6.5	0.38	0.688	MKM 5546	M6 x 30	115	0.4																																																																																																												
		J (mm)																																																																																																																									
13	1/2"	1636-06-06M							1.75							0.88	0.81	42	1.170	0.50	9.0	0.50	0.860	MKM 512	M8 x 35	210	0.5																																																																																																
		J (mm)																																																																																																																									
19	3/4"	1635-08-08M																			2.00							1.00	0.90	50	1.392	0.75	9.0	0.50	1.070	MKM 5559	M8 x 35	214	0.7																																																																																				
		J (mm)																																																																																																																									
25	1"	1636-08-08M																															2.50							1.25	1.00	62	1.726	1.00	11.0	0.50	1.335	MKM 503	M10 x 40	219	1.3																																																																								
		J (mm)																																																																																																																									
32	1-1/4"	1635-12-12M																																											3.00							1.50	1.20	73	2.032	1.25	13.5	0.50	1.680	MKM 1502	M12 x 50	222	2.2																																																												
		J (mm)																																																																																																																									
38	1-1/2"	1635-20-20M																																																							3.50							1.75	1.44	85	2.366	1.50	17.5	0.62	1.920	MKM 515	M16 x 60	225	3.4																																																
		J (mm)																																																																																																																									
51	2"	1636-12-12M																																																																			4.00							2.00	1.60	98	2.728	1.69	17.5	0.62	2.411	MKM 5560	M16 X 65	331	5.0																																				
		J (mm)																																																																																																																									
56	2-1/2"	1635-24-24M																																																																															4.75							2.38	1.98	118	3.285	2.12	22.0	0.75	2.911	MKM 5538	M20 X 80	335	8.5																								
		J (mm)																																																																																																																									
63	3"	1636-24-24M																																																																																											6.00							3.00	2.12	145	4.037	2.32	26.0	0.75	3.540	MKM 5561	M24 X 90	337	15.6												
		J (mm)																																																																																																																									
70	3-1/2"	1635-32-32M																																																																																																							6.50							3.25	2.46	160	4.454	2.73	26.0	0.75	4.045	MKM 5562	M24 X 100	340	21.3
		J (mm)																																																																																																																									
80	4"	1636-40-40M	7.00	3.50	2.85	175	4.872	3.15		33.0	0.75	4.550	MKM 5563	M30 X 120	341																																																																																																						26.8						
		J (mm)																																																																																																																									

Note: Dimensions are in Inches unless otherwise noted.

FLANGE PLUG

FLANGES -
CARBON STEEL

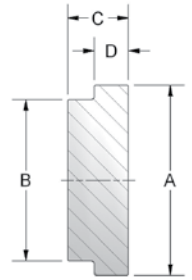
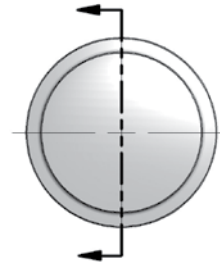
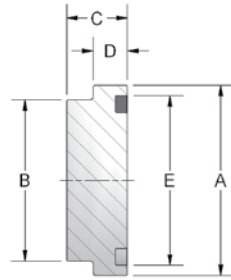

CODE 61 FLANGE PLUG

PART # O-RING FIG. 1	PART # FLAT FACE FIG. 2	FLANGE SIZE	A	B	C	D	E
8FOP	8FP	0.50	1.188	0.924	0.50	0.265	1.000
12FOP	12FP	0.75	1.500	1.234	0.56	0.265	1.250
16FOP	16FP	1.00	1.750	1.484	0.56	0.315	1.560
20FOP	20FP	1.25	2.000	1.684	0.56	0.315	1.750
24FOP	24FP	1.50	2.375	1.964	0.62	0.315	2.115
32FOP	32FP	2.00	2.810	2.434	0.62	0.375	2.490
40FOP	40FP	2.50	3.312	2.904	0.68	0.375	2.995
48FOP	48FP	3.00	4.000	3.534	0.75	0.375	3.615

CODE 62 FLANGE PLUG

PART # O-RING FIG. 1	PART # FLAT FACE FIG. 2	FLANGE SIZE	A	B	C	D	E
12FOPX	12FPX	0.75	1.625	1.234	0.690	0.345	1.250
16FOPX	16FPX	1.00	1.875	1.484	0.810	0.375	1.560
20FOPX	20FPX	1.25	2.125	1.704	1.000	0.405	1.750
24FOPX	24FPX	1.50	2.500	1.984	1.190	0.495	2.115
32FOPX	32FPX	2.00	3.125	2.604	1.500	0.495	2.490

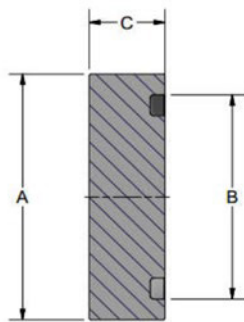

CAT - STYLE FLANGE PLUG

PART #	FLANGE SIZE	A	B	C	O-RING #
12COPX	0.75	1.625	1.234	0.690	0.345
16COPX	1.00	1.875	1.484	0.810	0.375
20COPX	1.25	2.125	1.704	1.000	0.405
24COPX	1.50	2.500	1.984	1.190	0.495
32COPX	2.00	3.125	2.604	1.500	0.495



FLANGES - STAINLESS STEEL

J518 SPLIT & CAPTIVE FLANGE

FLANGES -
STAINLESS STEEL

CODE 61 SPLIT FLANGE

* PART NO.	† KIT PART NO.	FLANGE SIZE	A	B	C	D	E	F	G	H	J	MOUNTING HARDWARE	
												O-RING	SHCS
8SF-2-SS	8SFO-SS	0.50	0.86	2.12	1.500	0.75	0.50	1.219	0.955	0.245	0.350	210	5/16-18X1.25
12SF-2-SS	12SFO-SS	0.75	0.98	2.56	1.875	0.88	0.56	1.531	1.265	0.245	0.417	214	3/8-16X1.25
16SF-2-SS	16SFO-SS	1.00	1.11	2.75	2.062	0.94	0.62	1.781	1.515	0.295	0.417	219	3/8-16X1.25
20SF-2-SS	20SFO-SS	1.25	1.39	3.12	2.312	0.88	0.56	2.031	1.720	0.295	0.472	222	7/16-14X1.50
24SF-2-SS	24SFO-SS	1.50	1.58	3.69	2.750	1.00	0.62	2.406	2.000	0.295	0.524	225	1/2-13X1.50
32SF-2-SS	32SFO-SS	2.00	1.86	4.00	3.062	1.03	0.62	2.844	2.470	0.355	0.524	228	1/2-13X1.50
40SF-2-SS	40SFO-SS	2.50	2.09	4.50	3.500	1.50	0.75	3.344	2.950	0.355	0.524	232	1/2-13X1.75
48SF-2-SS	48SFO-SS	3.00	2.53	5.31	4.188	1.62	0.88	4.031	3.580	0.355	0.657	237	5/8-11X1.75
56SF-2-SS	56SFO-SS	3.50	2.70	6.00	4.750	1.12	0.88	4.531	4.030	0.422	0.657	241	5/8-11X2.00
64SF-2-SS	64SFO-SS	4.00	2.95	6.38	5.125	1.38	1.00	5.031	4.530	0.422	0.657	245	5/8-11X2.00

CODE 62 SPLIT FLANGE

* PART NO.	† KIT PART NO.	FLANGE SIZE	A	B	C	D	E	F	G	H	J	MOUNTING HARDWARE	
												O-RING	SHCS
8SFX-2-SS	8SFXO-SS	0.50	0.89	2.22	1.594	0.88	0.62	1.281	0.970	0.285	0.350	210	5/16-18X1.25
12SFX-2-SS	12SFXO-SS	0.75	1.14	2.81	2.000	1.12	0.75	1.656	1.280	0.325	0.417	214	3/8-16X1.50
16SFX-2-SS	16SFXO-SS	1.00	1.33	3.19	2.250	1.31	0.94	1.906	1.530	0.355	0.472	219	7/16-14X1.75
20SFX-2-SS	20SFXO-SS	1.25	1.48	3.75	2.625	1.50	1.06	2.156	1.750	0.385	0.524	222	1/2-13X1.75
24SFX-2-SS	24SFXO-SS	1.50	1.83	4.44	3.125	1.69	1.19	2.531	2.030	0.475	0.657	225	5/8-11X2.25
32SFX-2-SS	32SFXO-SS	2.00	2.20	5.25	3.812	2.06	1.44	3.156	2.660	0.475	0.811	228	3/4-10X2.75

* Trilex Fluid Power includes: (1) split flange half only

† Kit part No. includes: (2) split flange halves, (4) hex head screws with flat washers, (1) Buna N O-Ring
Split flange halves are silver trivalent plated

CODE 61 CAPTIVE FLANGE

DRILLED NO.	TAPPED PART NO.	FLANGE SIZE	A	B	C	D	E	F	G	H	J	MOUNTING HARDWARE	
												O-RING	SHCS
8SFW-SS	8SFTW-SS	0.50	1.81	2.12	0.688	1.500	0.75	0.50	1.219	0.955	0.245	0.344	5/16-18
12SFW-SS	12SFTW-SS	0.75	2.06	2.56	0.875	1.875	0.88	0.56	1.531	1.265	0.245	0.406	3/8-16
16SFW-SS	16SFTW-SS	1.00	2.31	2.75	1.031	2.062	0.94	0.62	1.781	1.515	0.295	0.406	3/8-16
20SFW-SS	20SFTW-SS	1.25	2.88	3.12	1.188	2.312	0.88	0.56	2.031	1.720	0.295	0.469	7/16-14
24SFW-SS	24SFTW-SS	1.50	3.25	3.69	1.406	2.750	1.00	0.62	2.406	2.000	0.295	0.531	1/2-13
32SFW-SS	32SFTW-SS	2.00	3.81	4.00	1.688	3.062	1.03	0.62	2.844	2.470	0.355	0.531	1/2-13
40SFW-SS	40SFTW-SS	2.50	4.28	4.50	2.000	3.500	1.50	0.75	3.344	2.950	0.355	0.531	1/2-13
48SFW-SS	48SFTW-SS	3.00	5.16	5.31	2.438	4.188	1.62	0.88	4.031	3.580	0.355	0.656	5/8-11
56SFW-SS	56SFTW-SS	3.50	5.50	6.00	2.750	4.750	1.12	0.88	4.531	4.030	0.422	0.656	5/8-11
64SFW-SS	64SFTW-SS	4.00	6.00	6.38	3.062	5.125	1.38	1.00	5.031	4.530	0.422	0.656	5/8-11

CODE 62 CAPTIVE FLANGE

DRILLED NO.	TAPPED PART NO.	FLANGE SIZE	A	B	C	D	E	F	G	H	J	MOUNTING HARDWARE	
												O-RING	SHCS
8SFXW-SS	8SFXTW-SS	0.50	1.86	2.22	0.718	1.594	0.88	0.62	1.281	0.970	0.285	0.344	5/16-18
12SFXW-SS	12SFXTW-SS	0.75	2.38	2.81	0.937	2.000	1.12	0.75	1.656	1.280	0.325	0.406	3/8-16
16SFXW-SS	16SFXTW-SS	1.00	2.75	3.19	1.093	2.250	1.31	0.94	1.906	1.530	0.355	0.469	7/16-14
20SFXW-SS	20SFXTW-SS	1.25	3.06	3.75	1.250	2.625	1.50	1.06	2.156	1.750	0.385	0.531	1/2-13
24SFXW-SS	24SFXTW-SS	1.50	3.75	4.44	1.437	3.125	1.69	1.19	2.531	2.030	0.475	0.656	5/8-11
32SFXW-SS	32SFXTW-SS	2.00	4.50	5.25	1.750	3.812	2.06	1.44	3.156	2.660	0.475	0.781	3/4-10

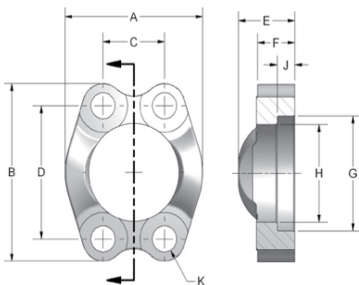
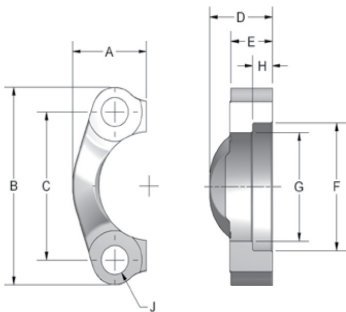

SPLIT FLANGE ADAPTERS

FLANGES -
STAINLESS STEEL

JIC THREAD

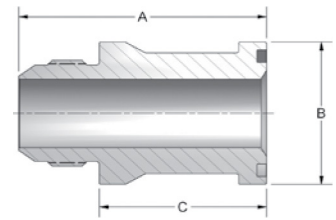

CODE 61 JIC THREAD

PART NO.	TUBE O.D.	FLANGE SIZE	A	B	C	THREAD
300-8-8-SS	1/2	1/2	2.60	1.188	1.94	3/4-16
300-8-12-SS	1/2	3/4	2.75	1.500	2.09	3/4-16
300-12-12-SS	3/4	3/4	2.75	1.500	1.89	1 1/16-12
300-16-12-SS	1	3/4	2.75	1.500	1.84	1 5/16-12
300-12-16-SS	3/4	1	2.80	1.750	1.94	1 1/16-12
300-16-16-SS	1	1	2.80	1.750	1.89	1 5/16-12
300-20-16-SS	1 1/4	1	2.80	1.750	1.84	1 5/8-12
300-12-20-SS	3/4	1 1/4	2.80	2.000	1.94	1 1/16-12
300-16-20-SS	1	1 1/4	2.80	2.000	1.89	1 5/16-12
300-20-20-SS	1 1/4	1 1/4	2.80	2.000	1.84	1 5/8-12
300-24-20-SS	1 1/2	1 1/4	3.40	2.000	2.32	1 7/8-12
300-16-24-SS	1	1 1/2	3.33	2.380	2.42	1 5/16-12
300-20-24-SS	1 1/4	1 1/2	3.38	2.375	2.42	1 5/8-12
300-24-24-SS	1 1/2	1 1/2	3.50	2.375	2.42	1 7/8-12
300-32-24-SS	2	1 1/2	4.20	2.375	2.87	2 1/2-12
300-20-32-SS	1 1/4	2	3.60	2.810	2.64	1 5/8-12
300-24-32-SS	1 1/2	2	3.73	2.812	2.64	1 7/8-12
300-32-32-SS	2	2	3.98	2.812	2.64	2 1/2-12
300-32-40-SS	2	2 1/2	3.98	3.312	2.64	2 1/2-12

CODE 62 JIC THREAD

PART NO.	TUBE O.D.	FLANGE SIZE	A	B	C	THREAD
600-8-8-SS	1/2	1/2	2.61	1.250	1.95	3/4-16
600-12-12-SS	3/4	3/4	2.75	1.625	1.89	1 1/16-12
600-16-12-SS	1	3/4	2.75	1.625	1.84	1 5/16-12
600-20-12-SS	1 1/4	3/4	3.05	1.625	2.09	1 5/8-12
600-12-16-SS	3/4	1	2.80	1.875	1.94	1 1/16-12
600-16-16-SS	1	1	2.80	1.875	1.89	1 5/16-12
600-20-16-SS	1 1/4	1	2.80	1.875	1.84	1 5/8-12
600-16-20-SS	1	1 1/4	3.05	2.125	2.14	1 5/16-12
600-20-20-SS	1 1/4	1 1/4	3.05	2.125	2.09	1 5/8-12
600-24-20-SS	1 1/2	1 1/4	3.30	2.125	2.22	1 7/8-12
600-16-24-SS	1	1 1/2	3.33	2.500	2.42	1 5/16-12
600-20-24-SS	1 1/4	1 1/2	3.50	2.500	2.54	1 5/8-12
600-24-24-SS	1 1/2	1 1/2	3.50	2.500	2.42	1 7/8-12
600-32-24-SS	2	1 1/2	4.94	2.500	3.61	2 1/2-12
600-24-32-SS	1 1/2	2	3.98	3.125	2.89	1 7/8-12
600-32-32-SS	2	2	4.23	3.125	2.89	2 1/2-12

SAE STRAIGHT THREAD

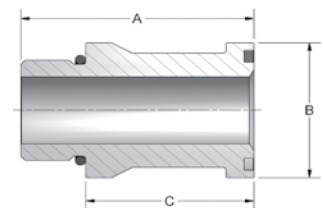

CODE 61 SAE STRAIGHT THREAD

PART NO.	TUBE O.D.	FLANGE SIZE	A	B	C	THREAD
302-8-8-SS	1/2	1/2	2.49	1.188	1.94	3/4-16
302-12-12-SS	3/4	3/4	2.61	1.500	1.89	1 1/16-12
302-16-12-SS	1	3/4	2.88	1.500	2.16	1 5/16-12
302-12-16-SS	3/4	1	2.74	1.750	2.02	1 1/16-12
302-16-16-SS	1	1	2.61	1.750	1.89	1 5/16-12
302-20-16-SS	1 1/4	1	3.13	1.750	2.41	1 5/8-12
302-16-20-SS	1	1 1/4	2.74	2.000	2.02	1 5/16-12
302-20-20-SS	1 1/4	1 1/4	3.13	2.000	2.41	1 5/8-12
302-24-20-SS	1 1/2	1 1/4	3.43	2.000	2.71	1 7/8-12
302-16-24-SS	1	1 1/2	3.30	2.380	2.58	1 5/16-12
302-20-24-SS	1 1/4	1 1/2	3.30	2.375	2.58	1 5/8-12
302-24-24-SS	1 1/2	1 1/2	3.14	2.375	2.42	1 7/8-12
302-24-32-SS	1 1/2	2	3.79	2.812	3.07	1 7/8-12
302-32-32-SS	2	2	3.63	2.812	2.91	2 1/2-12
302-40-40-SS	2 1/2	2 1/2	4.23	3.310	3.08	3-12
302-48-48-SS	3	3	4.50	4.000	3.36	3 1/2-12
302-64-64-SS	4	4	4.14	5.000	2.89	4 1/2-12

CODE 62 SAE STRAIGHT THREAD

PART NO.	TUBE O.D.	FLANGE SIZE	A	B	C	THREAD
602-8-8-SS	1/2	1/2	2.50	1.250	1.95	3/4-16
602-12-12-SS	3/4	3/4	2.62	1.625	1.89	1 1/16-12
602-16-12-SS	1	3/4	2.88	1.625	2.15	1 5/16-12
602-12-16-SS	3/4	1	2.75	1.875	2.02	1 1/16-12
602-16-16-SS	1	1	2.62	1.875	1.89	1 5/16-12
602-20-16-SS	1 1/4	1	3.44	1.875	2.71	1 5/8-12
602-16-20-SS	1	1 1/4	3.12	2.125	2.39	1 5/16-12
602-20-20-SS	1 1/4	1 1/4	3.00	2.125	2.27	1 5/8-12
602-24-20-SS	1 1/2	1 1/4	3.44	2.125	2.71	1 7/8-12
602-20-24-SS	1 1/4	1 1/2	3.31	2.500	2.58	1 5/8-12
602-24-24-SS	1 1/2	1 1/2	3.19	2.500	2.46	1 7/8-12
602-24-32-SS	1 1/2	2	3.90	3.125	3.17	1 7/8-12
602-32-32-SS	2	2	3.75	3.125	3.02	2 1/2-12

BLANKING

**FLANGES -
STAINLESS STEEL**

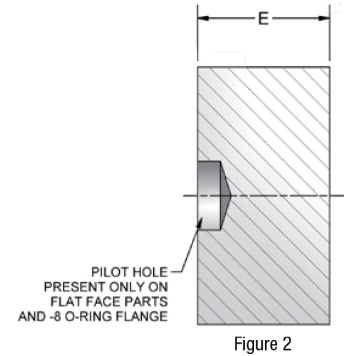
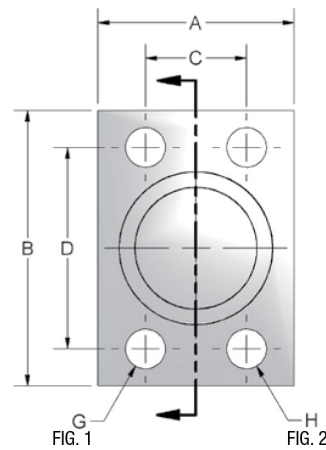
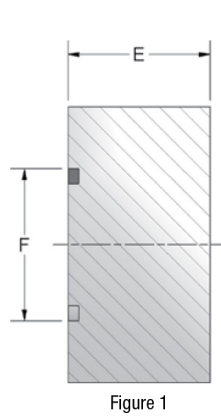
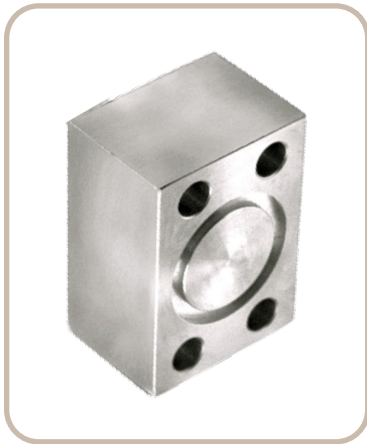

- Mounting kit available on o-ring grooved flanges by simply adding suffix letter 'U' to part number.

CODE 61 BLANKING

PART NO. O-RING FIG. 1	PART NO. FLAT FACE FIG. 2	PAD SIZE	A	B	C	D	E	F	G	H UNC-2B	MOUNTING HARDWARE	
											O-RING	SHCS
W36-8-8-SS	W37-8-8-SS	0.50	1.50	2.12	0.688	1.50	1.20	1.000	0.344	5/16-18	210	5/16-18X2.00
W36-12-12-SS	W37-12-12-SS	0.75	1.75	2.62	0.875	1.875	1.20	1.250	0.406	3/8-16	214	3/8-16X2.00
W36-16-16-SS	W37-16-16-SS	1.00	2.00	2.82	1.031	2.063	1.45	1.560	0.406	3/8-16	219	3/8-16X2.25
W36-20-20-SS	W37-20-20-SS	1.25	2.50	3.19	1.188	2.313	1.45	1.750	0.469	7/16-14	222	7/16-14X2.25
W36-24-24-SS	W37-24-24-SS	1.50	2.75	3.75	1.406	2.750	1.70	2.115	0.531	1/2-13	225	1/2-13X2.50
W36-32-32-SS	W37-32-32-SS	2.00	3.25	4.00	1.688	3.063	1.70	2.490	0.531	1/2-13	228	1/2-13X2.50
W36-40-40-SS	W37-40-40-SS	2.50	4.00	4.50	2.000	3.500	1.95	2.995	0.531	1/2-13	232	1/2-13X2.75
W36-48-48-SS	W37-48-48-SS	3.00	4.50	5.31	2.438	4.188	2.20	3.615	0.656	5/8-11	237	5/8-11X3.50
W36-56-56-SS	W37-56-56-SS	3.50	5.00	6.00	2.750	4.750	1.45	4.095	0.656	5/8-11	241	5/8-11X2.75
W36-64-64-SS	W37-64-64-SS	4.00	5.50	6.38	3.062	5.125	1.45	4.595	0.656	5/8-11	245	5/8-11X2.75

CODE 62 BLANKING

PART NO. O-RING FIG. 1	PART NO. FLAT FACE FIG. 2	PAD SIZE	A	B	C	D	E	F	G	H UNC-2B	MOUNTING HARDWARE	
											O-RING	SHCS
W38-8-8-SS	W39-8-8-SS	0.50	1.75	2.22	0.718	1.594	0.94	1.000	0.344	5/16-18	210	5/16-18X1.50
W38-12-12-SS	W39-12-12-SS	0.75	2.00	2.81	0.937	2.000	1.19	1.250	0.406	3/8-16	214	3/8-16X2.00
W38-16-16-SS	W39-16-16-SS	1.00	2.25	3.19	1.093	2.250	1.44	1.560	0.492	7/16-14	219	7/16-14X2.25
W38-20-20-SS	W39-20-20-SS	1.25	2.75	3.75	1.250	2.625	1.44	1.750	0.531	1/2-13	222	1/2-13X2.50
W38-24-24-SS	W39-24-24-SS	1.50	3.25	4.50	1.437	3.125	1.69	2.115	0.656	5/8-11	225	5/8-11X2.75
W38-32-32-SS	W39-32-32-SS	2.00	4.00	5.25	1.750	3.812	1.69	2.490	0.781	3/4-10	228	3/4-10X3.00
W38-40-40-SS	W39-40-40-SS	2.50	5.00	6.88	2.311	4.874	1.94	2.995	0.906	7/8-9	232	7/8-9X3.75
W38-48-48-SS	W39-48-48-SS	3.00	6.00	8.50	2.811	6.000	2.44	3.615	1.190	1 1/8-7	237	1 1/8-7X4.50

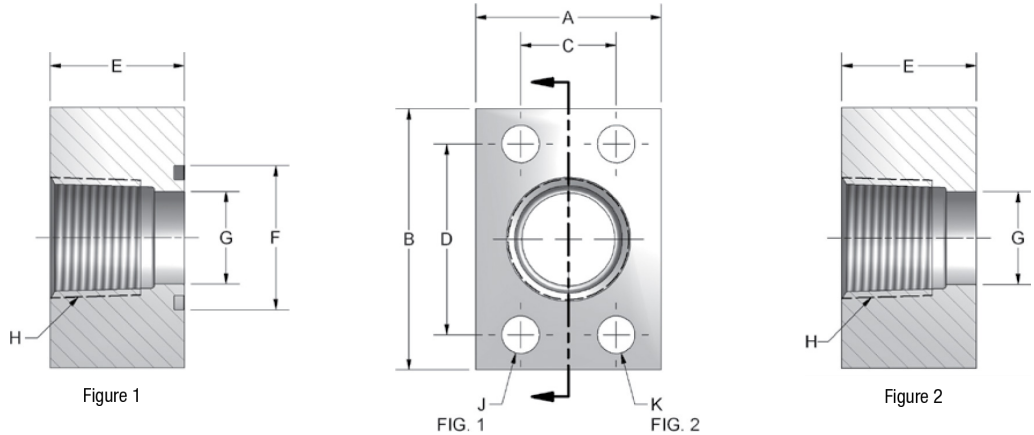

- Mounting kit available on o-ring grooved flanges by simply adding suffix letter 'U' to part number.

CODE 61 NPTF THREAD

PART NO. O-RING FIG. 1	PART NO. FLAT FACE FIG. 2	PIPE SIZE	PAD SIZE	A	B	C	D	E	F	G	H	J	K UNC-2B	MOUNTING HARDWARE	
														O-RING	SHCS
W43-8-8-SS	W104-8-8-SS	0.50	0.50	1.50	2.12	0.688	1.500	1.20	1.000	0.502	0.50	0.344	5/16-18	210	5-16-18X1.75
W43-12-12-SS	W104-12-12-SS	0.75	0.75	1.75	2.62	0.875	1.875	1.20	1.250	0.752	0.75	0.406	3/8-16	214	3/8-16X2.00
W43-16-16-SS	W104-16-16-SS	1.00	1.00	2.00	2.82	1.031	2.062	1.45	1.560	1.002	1.00	0.406	3/8-16	219	3/8-16X2.25
W43-20-20-SS	W104-20-20-SS	1.25	1.25	2.50	3.19	1.188	2.312	1.45	1.750	1.252	1.25	0.469	7/16-14	222	7/16-14X2.25
W43-24-24-SS	W104-24-24-SS	1.50	1.50	2.75	3.75	1.406	2.750	1.70	2.115	1.502	1.50	0.531	1/2-13	225	1/2-13X2.50
W43-32-32-SS	W104-32-32-SS	2.00	2.00	3.25	4.00	1.688	3.062	1.70	2.490	2.002	2.00	0.531	1/2-13	228	1/2-13X2.50
W43-40-40-SS	W104-40-40-SS	2.50	2.50	4.00	4.50	2.000	3.500	1.95	2.995	2.502	2.50	0.531	1/2-13	232	1/2-13X2.75
W43-48-48-SS	W104-48-48-SS	3.00	3.00	4.50	5.31	2.438	4.188	2.20	3.615	3.002	3.00	0.656	5/8-11	237	5/8-11X3.00

CODE 62 NPTF THREAD

PART NO. O-RING FIG. 1	PART NO. FLAT FACE FIG. 2	PIPE SIZE	PAD SIZE	A	B	C	D	E	F	G	H	J	K UNC-2B	MOUNTING HARDWARE	
														O-RING	SHCS
W44-8-8-SS	W45-8-8-SS	0.50	0.50	1.75	2.22	0.718	1.594	0.95	1.000	0.502	0.50	0.344	5/16-18	210	5/16-18X1.50
W44-12-12-SS	W45-12-12-SS	0.75	0.75	2.00	2.81	0.937	2.000	1.20	1.250	0.752	0.75	0.406	3/8-16	214	3/8-16X2.00
W44-16-16-SS	W45-16-16-SS	1.00	1.00	2.25	3.19	1.093	2.250	1.45	1.560	1.002	1.00	0.492	7/16-14	219	7/16-14X2.50
W44-20-20-SS	W45-20-20-SS	1.25	1.25	2.75	3.75	1.250	2.625	1.45	1.750	1.252	1.25	0.531	1/2-13	222	1/2-13X2.25
W44-24-24-SS	W45-24-24-SS	1.50	1.50	3.25	4.50	1.437	3.125	1.70	2.115	1.502	1.50	0.656	5/8-11	225	5/8-11X2.75
W44-32-32-SS	W45-32-32-SS	2.00	2.00	4.00	5.25	1.750	3.812	1.70	2.490	2.002	2.00	0.781	3/4-10	228	3/4-10X3.00

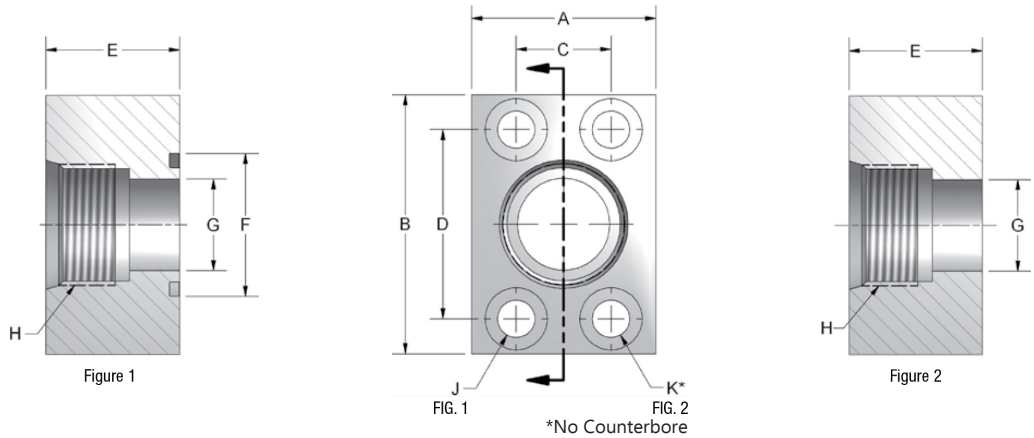

- Mounting kit available on o-ring grooved flanges by simply adding suffix letter 'U' to part number.

CODE 61 SAE STRAIGHT THREAD

PART NO. O-RING FIG. 1	PART NO. FLAT FACE FIG. 2	TUBE SIZE	PAD SIZE	A	B	C	D	E	F	G	H	J	K UNC-2B	MOUNTING HARDWARE	
														O-RING	SHCS
W46-8-8-SS	W106-8-8-SS	0.50	0.50	1.50	2.12	0.688	1.500	1.20	1.000	0.502	3/4-16	0.344	5/16-18	210	5-16-18X1.25
W46-12-12-SS	W106-12-12-SS	0.75	0.75	1.75	2.62	0.875	1.875	1.20	1.250	0.752	1 1/16-12	0.406	3/8-16	214	3/8-16X1.50
W46-16-16-SS	W106-16-16-SS	1.00	1.00	2.00	2.82	1.031	2.062	1.45	1.560	1.002	1 5/16-12	0.406	3/8-16	219	3/8-16X1.50
W46-20-20-SS	W106-20-20-SS	1.25	1.25	2.50	3.19	1.188	2.312	1.45	1.750	1.252	1 5/8-12	0.469	7/16-14	222	7/16-14X1.75
W46-24-24-SS	W106-24-24-SS	1.50	1.50	2.75	3.75	1.406	2.750	1.70	2.115	1.502	1 7/8-12	0.531	1/2-13	225	1/2-13X2.00
*W46-32-32-SS	W106-32-32-SS	2.00	2.00	3.25	4.00	1.688	3.062	1.70	2.490	2.002	2 1/2-12	0.531	1/2-13	228	1/2-13X2.00
**W46-40-40-SS	W106-40-40-SS	2.50	2.50	4.00	4.50	2.00	3.50	1.95	3.000	2.500	3-12	0.530	1/2-13	232	1/2-13X2.25
**W46-48-48-SS	W106-48-48-SS	3.00	3.00	4.50	5.31	2.44	4.19	2.20	3.62	3.000	3 1/2-12	0.660	5/8-11	237	5/8-11X2.25
**W46-64-64-SS	W106-64-64-SS	4.00	4.00	5.50	6.38	3.06	5.13	1.45	4.60	4.000	4 1/2-12	0.660	5/8-11	245	5/8-11X1.50

*1000 PSI max for W46-32-32-SS
** Consult Factory For Working Pressure

CODE 62 SAE STRAIGHT THREAD

PART NO. O-RING FIG. 1	PART NO. FLAT FACE FIG. 2	TUBE SIZE	PAD SIZE	A	B	C	D	E	F	G	H	J	K UNC-2B	MOUNTING HARDWARE	
														O-RING	SHCS
W48-8-8-SS	W49-8-8-SS	0.50	0.50	1.75	2.22	0.718	1.594	0.95	1.000	0.502	3/4-16	0.344	5/16-18	210	5/16-18X1.25
W48-12-12-SS	W49-12-12-SS	0.75	0.75	2.00	2.81	0.937	2.000	1.20	1.250	0.752	1 1/16-12	0.406	3/8-16	214	3/8-16X1.50
W48-16-16-SS	W49-16-16-SS	1.00	1.00	2.25	3.19	1.093	2.250	1.45	1.560	1.002	1 5/16-12	0.492	7/16-14	219	7/16-14X1.75
W48-20-20-SS	W49-20-20-SS	1.25	1.25	2.75	3.75	1.250	2.625	1.45	1.750	1.252	1 5/8-12	0.531	1/2-13	222	1/2-13X1.50
W48-24-24-SS	W49-24-24-SS	1.50	1.50	3.25	4.50	1.437	3.125	1.70	2.115	1.502	1 7/8-12	0.656	5/8-11	225	5/8-11X2.00
W48-32-32-SS	W49-32-32-SS	2.00	2.00	4.00	5.25	1.750	3.812	1.70	2.490	2.002	2 1/2-12	0.781	3/4-10	228	3/4-10X2.00

FLAT SOCKET WELD PIPE

FLANGES -
STAINLESS STEEL

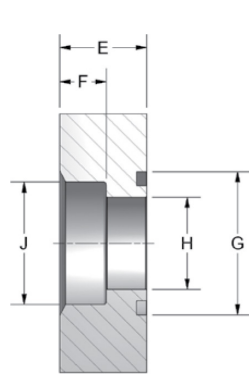

Figure 1

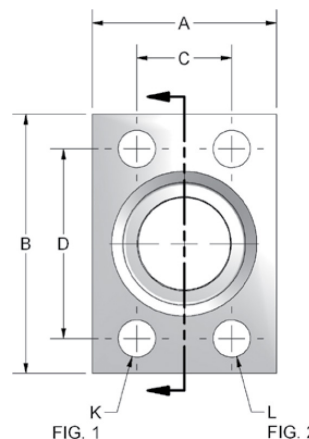

FIG. 1

FIG. 2

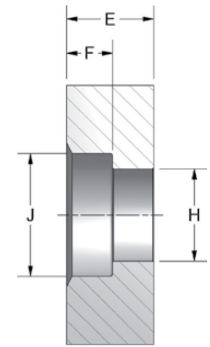

Figure 2

- Mounting kit available on o-ring grooved flanges by simply adding suffix letter 'U' to part number.

CODE 61 FLAT SOCKET WELD - PIPE

PART NO. O-RING FIG. 1	PART NO. FLAT FACE FIG. 2	PIPE SIZE	PAD SIZE	A	B	C	D	E	F	G	H	J	K	L UNC-2B	MOUNTING HARDWARE	
															O-RING	SHCS
W4-8-8-SS	W61-8-8-SS	0.50	0.50	1.50	2.12	0.688	1.500	0.69	0.38	1.000	0.502	0.860	0.344	5/16-18	210	5/16-18X1.25
W4-12-12-SS	W61-12-12-SS	0.75	0.75	1.75	2.62	0.875	1.875	0.94	0.50	1.250	0.752	1.070	0.406	3/8-16	214	3/8-16X1.75
W4-16-16-SS	W61-16-16-SS	1.00	1.00	2.00	2.82	1.031	2.062	0.94	0.50	1.560	1.002	1.335	0.406	3/8-16	219	3/8-16X1.75
W4-20-20-SS	W61-20-20-SS	1.25	1.25	2.50	3.19	1.188	2.312	0.94	0.50	1.750	1.252	1.680	0.469	7/16-14	222	7/16-14X1.75
W4-24-24-SS	W61-24-24-SS	1.50	1.50	2.75	3.75	1.406	2.750	1.19	0.50	2.115	1.502	1.920	0.531	1/2-13	225	1/2-13X2.25
W4-32-32-SS	W61-32-32-SS	2.00	2.00	3.25	4.00	1.688	3.062	1.44	0.62	2.490	2.002	2.411	0.531	1/2-13	228	1/2-13X2.50
W4-40-40-SS	W61-40-40-SS	2.50	2.50	4.00	4.50	2.000	3.500	1.69	0.75	2.995	2.502	2.911	0.531	1/2-13	232	1/2-13X2.75
W4-48-48-SS	W61-48-48-SS	3.00	3.00	4.50	5.31	2.438	4.188	2.12	1.24	3.615	3.002	3.540	0.656	5/8-11	237	5/8-11X3.50

CODE 62 FLAT SOCKET WELD - PIPE

PART NO. O-RING FIG. 1	PART NO. FLAT FACE FIG. 2	PIPE SIZE	PAD SIZE	A	B	C	D	E	F	G	H	J	K	L UNC-2B	MOUNTING HARDWARE	
															O-RING	SHCS
W59-8-8-SS	W60-8-8-SS	0.50	0.50	1.75	2.22	0.718	1.594	0.940	0.50	1.000	0.502	0.860	0.344	5/16-18	210	5/16-18X1.50
W59-12-12-SS	W60-12-12-SS	0.75	0.75	2.00	2.81	0.937	2.000	0.940	0.50	1.250	0.752	1.070	0.406	3/8-16	214	3/8-16X1.75
W59-16-16-SS	W60-16-16-SS	1.00	1.00	2.25	3.19	1.093	2.250	0.940	0.50	1.560	1.002	1.335	0.492	7/16-14	219	7/16-14X1.75
W59-20-20-SS	W60-20-20-SS	1.25	1.25	2.75	3.75	1.250	2.625	1.19	0.50	1.750	1.252	1.672	0.531	1/2-13	222	1/2-13X2.25
W59-24-24-SS	W60-24-24-SS	1.50	1.50	3.25	4.50	1.437	3.125	1.44	0.50	2.115	1.502	1.920	0.656	5/8-11	225	5/8-11X2.75
W59-32-32-SS	W60-32-32-SS	2.00	2.00	4.00	5.25	1.750	3.812	1.69	0.62	2.490	2.002	2.411	0.781	3/4-10	228	3/4-10X3.00
W59-40-40-SS	W60-40-40-SS	2.50	2.50	5.00	6.88	2.311	4.874	1.94	0.62	2.995	2.502	2.911	0.906	7/8-9	232	7/8-9X3.50
W59-48-48-SS	W60-48-48-SS	3.00	3.00	6.00	8.50	2.811	6.000	2.44	0.62	3.615	3.002	3.540	1.190	1-1/8-7	237	1-1/8-7X4.50

CODE 61 FLAT SOCKET WELD - PIPE - ALL SIZES 500 PSI

PART NO. O-RING FIG. 1	PART NO. FLAT FACE FIG. 2	PIPE SIZE	PAD SIZE	A	B	C	D	E	F	G	H	J	K	L UNC-2B	MOUNTING HARDWARE	
															O-RING	SHCS
W72-48-48-SS	W91-48-48-SS	3.00	3.00	4.50	5.31	2.438	4.188	1.38	1.13	3.615	3.002	3.540	0.656	5/8-11	237	5/8-11X2.50
W72-56-56-SS	W91-56-56-SS	3.50	3.50	5.00	6.00	2.750	4.750	1.44	1.19	4.095	3.502	4.054	0.656	5/8-11	241	5/8-11X2.50
W72-64-64-SS	W91-64-64-SS	4.00	4.00	5.50	6.38	3.062	5.125	1.450	1.20	4.595	4.002	4.550	0.656	5/8-11	245	5/8-11X2.50

DEEP SOCKET WELD PIPE

FLANGES -
STAINLESS STEEL

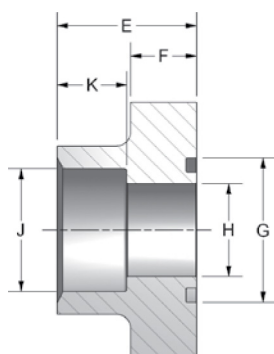

Figure 1

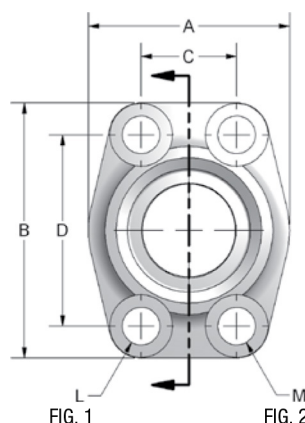

FIG. 1

FIG. 2

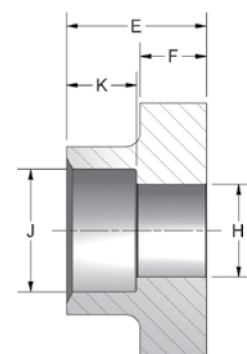

Figure 2

- Mounting kit available on o-ring grooved flanges by simply adding suffix letter 'U' to part number.

CODE 61 DEEP SOCKET WELD - PIPE

PART NO. O-RING FIG. 1	PART NO. FLAT FACE FIG. 2	PIPE SIZE	PAD SIZE	A	B	C	D	E	F	G	H	J	K	L	M UNC-2B	MOUNTING HARDWARE	
																O-RING	SHCS
W31-8-8-SS	W3-8-8-SS	0.50	0.50	1.81	2.13	0.688	1.500	1.42	0.63	1.000	0.502	0.855	0.75	0.344	5/16-18	210	5/16-18X1.25
W31-12-12-SS	W3-12-12-SS	0.75	0.75	1.97	2.56	0.875	1.875	1.42	0.71	1.250	0.752	1.062	0.75	0.406	3/8-16	214	3/8-16X1.50
W31-16-16-SS	W3-16-16-SS	1.00	1.00	2.17	2.75	1.031	2.062	1.50	0.71	1.560	1.002	1.328	0.75	0.406	3/8-16	219	3/8-16X1.50
W31-20-20-SS	W3-20-20-SS	1.25	1.25	2.68	3.12	1.188	2.312	1.61	0.83	1.750	1.252	1.672	0.87	0.469	7/16-14	222	7/16-14X1.75
W31-24-24-SS	W3-24-24-SS	1.50	1.50	3.07	3.66	1.406	2.750	1.77	0.98	2.115	1.502	1.922	0.94	0.531	1/2-13	225	1/2-13X1.75
W31-32-32-SS	W3-32-32-SS	2.00	2.00	3.54	4.00	1.688	3.062	1.77	0.98	2.490	2.002	2.406	1.02	0.531	1/2-13	228	1/2-13X1.75
W31-40-40-SS	W3-40-40-SS	2.50	2.50	4.09	4.49	2.000	3.500	1.97	0.98	2.995	2.502	2.908	1.18	0.531	1/2-13	232	1/2-13X1.75
W31-48-48-SS	W3-48-48-SS	3.00	3.00	4.88	5.28	2.438	4.188	1.97	1.06	3.615	3.002	3.547	1.34	0.656	5/8-11	237	5/8-11X2.00

CODE 62 DEEP SOCKET WELD - PIPE

PART NO. O-RING FIG. 1	PART NO. FLAT FACE FIG. 2	PIPE SIZE	PAD SIZE	A	B	C	D	E	F	G	H	J	K	L	M UNC-2B	MOUNTING HARDWARE	
																O-RING	SHCS
W81-8-8-SS	W80-8-8-SS	0.50	0.50	1.81	2.21	0.718	1.594	1.42	0.63	1.000	0.502	0.855	0.75	0.344	5/16-18	210	5/16-18X1.25
W81-12-12-SS	W80-12-12-SS	0.75	0.75	2.17	2.80	0.937	2.000	1.38	0.83	1.250	0.752	1.062	0.87	0.406	3/8-16	214	3/8-16X1.50
W81-16-16-SS	W80-16-16-SS	1.00	1.00	2.56	3.19	1.093	2.250	1.65	0.98	1.560	1.002	1.328	0.87	0.492	7/16-14	219	7/16-14X1.75
W81-20-20-SS	W80-20-20-SS	1.25	1.25	3.07	3.75	1.250	2.625	1.77	1.06	1.750	1.252	1.672	0.98	0.531	1/2-13	222	1/2-13X1.75
W81-24-24-SS	W80-24-24-SS	1.50	1.50	3.70	4.41	1.437	3.125	1.97	1.18	2.115	1.502	1.922	1.10	0.656	5/8-11	225	5/8-11X2.25
W81-32-32-SS	W80-32-32-SS	2.00	2.00	4.50	5.28	1.750	3.812	2.56	1.46	2.490	2.002	2.406	0.94	0.781	3/4-10	228	3/4-10X2.75

BUTT WELD PIPE

**FLANGES -
STAINLESS STEEL**

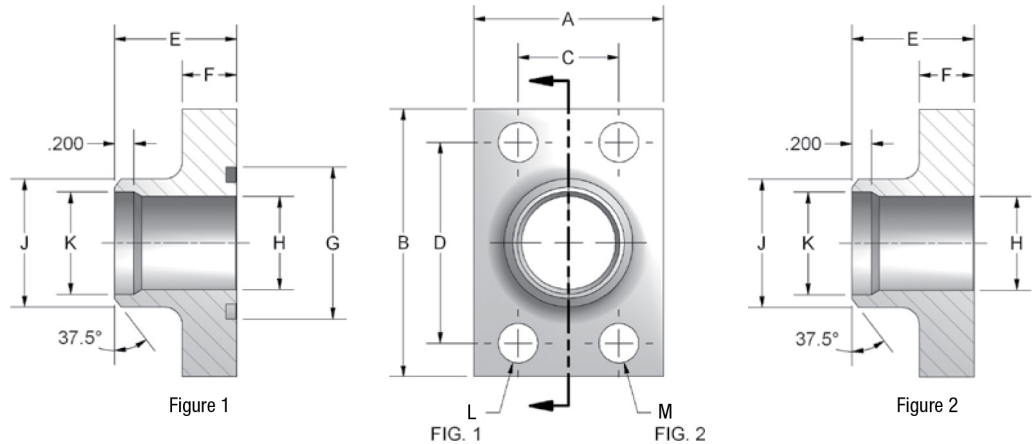
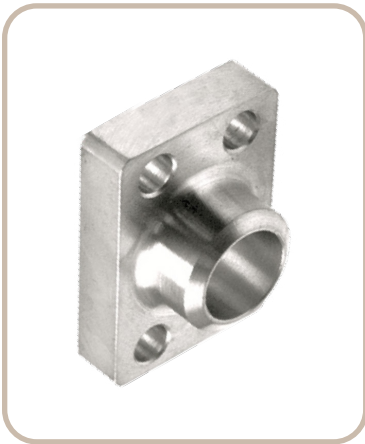

- Mounting kit available on o-ring grooved flanges by simply adding suffix letter 'U' to part number.

CODE 61 BUTT WELD - SCHEDULE 40 PIPE

PART NO. O-RING FIG. 1	PART NO. FLAT FACE FIG. 2	PIPE SIZE	PAD SIZE	A	B	C	D	E	F	G	H	J	K	L	M UNC-2B	MOUNTING HARDWARE	
																O-RING	SHCS
W35-8-SS	W34-8-SS	0.50	0.50	1.47	2.09	0.688	1.500	1.06	0.50	1.000	0.548	0.840	0.624	0.344	5/16-18	210	5/16-18X1.25
W35-12-SS	W34-12-SS	0.75	0.75	1.69	2.56	0.875	1.875	1.06	0.50	1.250	0.744	1.050	0.826	0.406	3/8-16	214	3/8-16X1.25
W35-16-SS	W34-16-SS	1.00	1.00	1.94	2.75	1.031	2.062	1.25	0.56	1.560	0.959	1.315	1.051	0.406	3/8-16	219	3/8-16X1.25
W35-20-SS	W34-20-SS	1.25	1.25	2.19	3.12	1.188	2.312	1.44	0.62	1.750	1.280	1.660	1.382	0.469	7/16-14	222	7/16-14X1.50
W35-24-SS	W34-24-SS	1.50	1.50	2.56	3.69	1.406	2.750	1.75	0.81	2.115	1.502	1.900	1.612	0.531	1/2-13	225	1/2-13X1.75
W35-32-SS	W34-32-SS	2.00	2.00	3.06	4.00	1.688	3.062	2.00	1.06	2.490	1.941	2.375	2.069	0.531	1/2-13	228	1/2-13X2.00
W35-40-SS	W34-40-SS	2.50	2.50	3.56	4.50	2.000	3.500	2.31	1.12	2.995	2.325	2.875	2.471	0.531	1/2-13	232	1/2-13X2.00
W35-48-SS	W34-48-SS	3.00	3.00	4.19	5.31	2.438	4.188	2.75	1.62	3.615	2.902	3.500	3.070	0.656	5/8-11	237	5/8-11X2.75
W35-56-SS	W34-56-SS	3.50	3.50	5.00	6.00	2.750	4.750	1.50	1.00	4.095	3.366	4.000	3.550	0.656	5/8-11	241	5/8-11X2.00
W35-64-SS	W34-64-SS	4.00	4.00	5.50	6.38	3.062	5.125	1.50	1.00	4.595	3.828	4.500	4.028	0.656	5/8-11	245	5/8-11X2.00
W35-80-SS	W34-80-SS	5.00	5.00	7.00	7.25	3.625	6.000	2.00	1.25	5.595	4.81	5.62	5.078	0.660	5/8-11	253	5/8-11X2.50

CODE 61 BUTT WELD - SCHEDULE 80 PIPE

PART NO. O-RING FIG. 1	PART NO. FLAT FACE FIG. 2	PIPE SIZE	PAD SIZE	A	B	C	D	E	F	G	H	J	K	L	M UNC-2B	MOUNTING HARDWARE	
																O-RING	SHCS
W24-8-SS	W23-8-SS	0.50	0.50	1.50	2.12	0.688	1.500	1.06	0.50	1.000	0.546	0.840	SCHEDULE 40 ONLY	0.344	5/16-18	210	5/16-18X1.25
W24-12-SS	W23-12-SS	0.75	0.75	1.69	2.56	0.875	1.875	1.06	0.50	1.250	0.752	1.050		0.406	3/8-16	214	3/8-16X1.25
W24-16-SS	W23-16-SS	1.00	1.00	1.94	2.75	1.031	2.062	1.25	0.56	1.560	0.959	1.315		0.406	3/8-16	219	3/8-16X1.25
W24-20-SS	W23-20-SS	1.25	1.25	2.19	3.12	1.188	2.312	1.44	0.62	1.750	1.280	1.660		0.469	7/16-14	222	7/16-14X1.50
W24-24-SS	W23-24-SS	1.50	1.50	2.56	3.69	1.406	2.750	1.75	0.81	2.115	1.502	1.900		0.531	1/2-13	225	1/2-13X1.75
W24-32-SS	W23-32-SS	2.00	2.00	3.06	4.00	1.688	3.062	2.00	1.06	2.490	1.941	2.375		0.531	1/2-13	228	1/2-13X2.00
W24-40-SS	W23-40-SS	2.50	2.50	3.56	4.50	2.000	3.500	2.31	1.12	2.995	2.325	2.875		0.531	1/2-13	232	1/2-13X2.00
W24-48-SS	W23-48-SS	3.00	3.00	4.19	5.31	2.438	4.188	2.75	1.62	3.615	2.902	3.500		0.656	5/8-11	237	5/8-11X2.75

CODE 61 BUTT WELD - SCHEDULE 160 PIPE

PART NO. O-RING FIG. 1	PART NO. FLAT FACE FIG. 2	PIPE SIZE	PAD SIZE	A	B	C	D	E	F	G	H	J	K	L	M UNC-2B	MOUNTING HARDWARE	
																O-RING	SHCS
W27-8-SS	W25-8-SS	0.50	0.50	1.50	2.12	0.688	1.500	1.06	0.50	1.000	0.466	0.840	SCHEDULE 40 ONLY	0.344	5/16-18	210	5/16-18X1.25
W27-12-SS	W25-12-SS	0.75	0.75	1.69	2.56	0.875	1.875	1.06	0.50	1.250	0.616	1.050		0.406	3/8-16	214	3/8-16X1.25
W27-16-SS	W25-16-SS	1.00	1.00	1.94	2.75	1.031	2.062	1.25	0.56	1.560	0.817	1.315		0.406	3/8-16	219	3/8-16X1.25
W27-20-SS	W25-20-SS	1.25	1.25	2.19	3.12	1.188	2.312	1.44	0.62	1.750	1.162	1.660		0.469	7/16-14	222	7/16-14X1.50
W27-24-SS	W25-24-SS	1.50	1.50	2.56	3.69	1.406	2.750	1.75	0.81	2.115	1.339	1.900		0.531	1/2-13	225	1/2-13X1.75
W27-32-SS	W25-32-SS	2.00	2.00	3.06	4.00	1.688	3.062	2.00	1.06	2.490	1.691	2.375		0.531	1/2-13	228	1/2-13X2.00
W27-40-SS	W25-40-SS	2.50	2.50	3.56	4.50	2.000	3.500	2.31	1.12	2.995	2.127	2.875		0.531	1/2-13	232	1/2-13X2.00
W27-48-SS	W25-48-SS	3.00	3.00	4.19	5.31	2.438	4.188	2.75	1.62	3.615	2.626	3.500		0.656	5/8-11	237	5/8-11X2.75

BUTT WELD PIPE

**FLANGES -
STAINLESS STEEL**

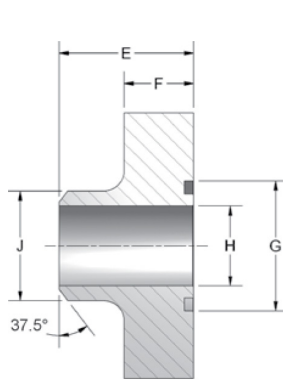

Figure 1

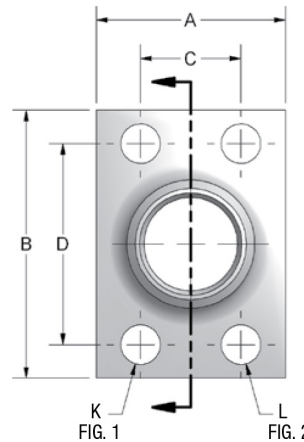

Figure 2

- Mounting kit available on o-ring grooved flanges by simply adding suffix letter 'U' to part number.

CODE 62 BUTT WELD - SCHEDULE 80 PIPE

PART NO. O-RING FIG. 1	PART NO. FLAT FACE FIG. 2	PIPE SIZE	PAD SIZE	A	B	C	D	E	F	G	H	J	K	L UNC-2B	MOUNTING HARDWARE	
															O-RING	SHCS
W28-8-SS	W26-8-SS	0.50	0.50	1.75	2.22	0.718	1.594	1.25	0.776	1.000	0.548	0.840	0.344	5/16-18	210	5/16-18X1.50
W28-12-SS	W26-12-SS	0.75	0.75	1.94	2.81	0.937	2.000	1.42	0.83	1.250	0.744	1.050	0.406	3/8-16	214	3/8-16X1.50
W28-16-SS	W26-16-SS	1.00	1.00	2.18	3.19	1.093	2.250	1.61	0.83	1.560	0.959	1.315	0.492	7/16-14	219	7/16-14X1.50
W28-20-SS	W26-20-SS	1.25	1.25	2.44	3.75	1.250	2.625	1.73	0.94	1.750	1.280	1.660	0.531	1/2-13	222	1/2-13X2.00
W28-24-SS	W26-24-SS	1.50	1.50	2.81	4.44	1.437	3.125	2.17	1.10	2.115	1.502	1.900	0.656	5/8-11	225	5/8-11X2.25
W28-32-SS	W26-32-SS	2.00	2.00	3.44	5.25	1.750	3.812	2.48	1.46	2.490	1.941	2.375	0.781	3/4-10	228	3/4-10X3.00
W28-40-SS	W26-40-SS	2.50	2.50	5.00	6.88	2.311	4.874	2.37	1.50	2.995	2.325	2.875	0.940	7/8-9	232	7/8-9X3.00
W28-48-SS	W26-48-SS	3.00	3.00	6.00	8.50	2.811	6.000	2.96	2.00	3.615	2.902	3.500	1.190	1-1/8-7	237	1-1/8-7X4.00

CODE 62 BUTT WELD - SCHEDULE 160 PIPE

PART NO. O-RING FIG. 1	PART NO. FLAT FACE FIG. 2	PIPE SIZE	PAD SIZE	A	B	C	D	E	F	G	H	J	K	L UNC-2B	MOUNTING HARDWARE	
															O-RING	SHCS
W30-12-SS	W29-12-SS	0.75	0.75	1.94	2.81	0.937	2.000	1.42	0.83	1.250	0.616	1.050	0.406	3/8-16	214	3/8-16X1.50
W30-16-SS	W29-16-SS	1.00	1.00	2.18	3.19	1.093	2.250	1.61	0.83	1.560	0.817	1.315	0.492	7/16-14	219	7/16-14X1.50
W30-20-SS	W29-20-SS	1.25	1.25	2.44	3.75	1.250	2.625	1.73	0.94	1.750	1.162	1.660	0.531	1/2-13	222	1/2-13X2.00
W30-24-SS	W29-24-SS	1.50	1.50	2.81	4.44	1.437	3.125	2.17	1.10	2.115	1.339	1.900	0.656	5/8-11	225	5/8-11X2.25
W30-32-SS	W29-32-SS	2.00	2.00	3.44	5.25	1.750	3.812	2.48	1.46	2.490	1.691	2.375	0.781	3/4-10	228	3/4-10X3.00
W30-40-SS	W29-40-SS	2.50	2.50	5.00	6.88	2.311	4.874	2.37	1.50	2.995	2.127	2.875	0.940	7/8-9	232	7/8-9X3.00
W30-48-SS	W29-48-SS	3.00	3.00	6.00	8.50	2.811	6.000	2.96	2.00	3.615	2.626	3.500	1.190	1-1/8-7	237	1-1/8-7X4.00

CODE 62 BUTT WELD - SCHEDULE XXS PIPE

PART NO. O-RING FIG. 1	PART NO. FLAT FACE FIG. 2	PIPE SIZE	PAD SIZE	A	B	C	D	E	F	G	H	J	K	L UNC-2B	MOUNTING HARDWARE	
															O-RING	SHCS
W33-12-SS	W32-12-SS	0.75	0.75	1.94	2.81	0.937	2.000	1.42	0.83	1.250	0.436	1.050	0.406	3/8-16	214	3/8-16X1.50
W33-16-SS	W32-16-SS	1.00	1.00	2.18	3.19	1.093	2.250	1.61	0.83	1.560	0.601	1.315	0.492	7/16-14	219	7/16-14X1.50
W33-20-SS	W32-20-SS	1.25	1.25	2.44	3.75	1.250	2.625	1.73	0.94	1.750	0.898	1.660	0.531	1/2-13	222	1/2-13X2.00
W33-24-SS	W32-24-SS	1.50	1.50	2.81	4.44	1.437	3.125	2.17	1.10	2.115	1.102	1.900	0.656	5/8-11	225	5/8-11X2.25
W33-32-SS	W32-32-SS	2.00	2.00	3.44	5.25	1.750	3.812	2.48	1.46	2.490	1.505	2.375	0.781	3/4-10	228	3/4-10X3.00
W33-40-SS	W32-40-SS	2.50	2.50	5.00	6.88	2.311	4.874	2.37	1.50	2.995	1.773	2.875	0.940	7/8-9	232	7/8-9X3.00
W33-48-SS	W32-48-SS	3.00	3.00	6.00	8.50	2.811	6.000	2.96	2.00	3.615	2.302	3.500	1.190	1-1/8-7	237	1-1/8-7X4.00

BUTT WELD FLANGE HEAD

FLANGES -
STAINLESS STEEL

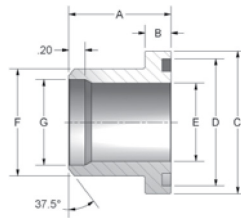

FIGURE 1

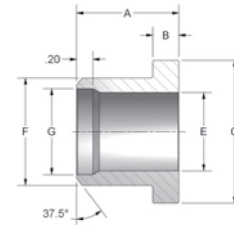

FIGURE 2

CODE 61 BUTT WELD TO FLANGE HEAD FOR SCHEDULE 40 PIPE

PART NO. O-RING FIG. 1	PART NO. FLAT FACE FIG. 2	PIPE SIZE	CLAMP SIZE	A	B	C	D	E	F	G
8P-8BWSF-40-SS	8P-8BWSFN-40-SS	0.50	0.50	1.06	0.265	1.188	1.000	0.548	0.840	0.624
12P-12BWSF-40-SS	12P-12BWSFN-40-SS	0.75	0.75	1.06	0.265	1.500	1.250	0.744	1.050	0.826
16P-16BWSF-40-SS	16P-16BWSFN-40-SS	1.00	1.00	1.25	0.315	1.750	1.560	0.959	1.315	1.051
20P-20BWSF-40-SS	20P-20BWSFN-40-SS	1.25	1.25	1.44	0.315	2.000	1.750	1.280	1.660	1.382
24P-24BWSF-40-SS	24P-24BWSFN-40-SS	1.50	1.50	1.75	0.315	2.375	2.115	1.502	1.900	1.612
32P-32BWSF-40-SS	32P-32BWSFN-40-SS	2.00	2.00	2.00	0.375	2.812	2.490	1.941	2.375	2.069
40P-40BWSF-40-SS	40P-40BWSFN-40-SS	2.50	2.50	2.31	0.375	3.312	2.995	2.325	2.875	2.471
48P-48BWSF-40-SS	48P-48BWSFN-40-SS	3.00	3.00	2.31	0.375	4.000	3.615	2.902	3.500	3.070
64P-64BWSF-40-SS	64P-64BWSFN-40-SS	4.00	4.00	1.90	0.442	5.000	4.595	3.828	4.500	4.028



CODE 61 BUTT WELD TO FLANGE HEAD FOR SCHEDULE 80 PIPE

PART NO. O-RING FIG. 1	PART NO. FLAT FACE FIG. 2	PIPE SIZE	CLAMP SIZE	A	B	C	D	E	F
8P-8BWSF-80-SS	8P-8BWSFN-80-SS	0.50	0.50	1.06	0.265	1.188	1.000	0.548	0.840
12P-12BWSF-80-SS	12P-12BWSFN-80-SS	0.75	0.75	1.06	0.265	1.500	1.250	0.744	1.050
16P-16BWSF-80-SS	16P-16BWSFN-80-SS	1.00	1.00	1.25	0.315	1.750	1.560	0.959	1.315
20P-20BWSF-80-SS	20P-20BWSFN-80-SS	1.25	1.25	1.44	0.315	2.000	1.750	1.280	1.660
24P-24BWSF-80-SS	24P-24BWSFN-80-SS	1.50	1.50	1.75	0.315	2.375	2.115	1.502	1.900
32P-32BWSF-80-SS	32P-32BWSFN-80-SS	2.00	2.00	2.00	0.375	2.812	2.490	1.941	2.375
40P-40BWSF-80-SS	40P-40BWSFN-80-SS	2.50	2.50	2.31	0.375	3.312	2.995	2.325	2.875
48P-48BWSF-80-SS	48P-48BWSFN-80-SS	3.00	3.00	2.31	0.375	4.000	3.615	2.902	3.500

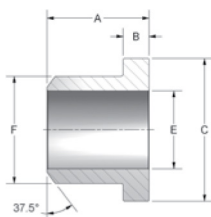

FIGURE 1

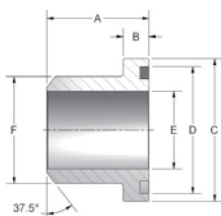

FIGURE 2

CODE 61 BUTT WELD TO FLANGE HEAD FOR SCHEDULE 160 PIPE

PART NO. O-RING FIG. 1	PART NO. FLAT FACE FIG. 2	PIPE SIZE	CLAMP SIZE	A	B	C	D	E	F
8P-8BWSF-160-SS	8P-8BWSFN-160-SS	0.50	0.50	1.06	0.265	1.188	1.000	0.464	0.840
12P-12BWSF-160-SS	12P-12BWSFN-160-SS	0.75	0.75	1.06	0.265	1.500	1.250	0.612	1.050
16P-16BWSF-160-SS	16P-16BWSFN-160-SS	1.00	1.00	1.25	0.315	1.750	1.560	0.815	1.315
20P-20BWSF-160-SS	20P-20BWSFN-160-SS	1.25	1.25	1.44	0.315	2.000	1.750	1.160	1.660
24P-24BWSF-160-SS	24P-24BWSFN-160-SS	1.50	1.50	1.75	0.315	2.375	2.115	1.338	1.900
32P-32BWSF-160-SS	32P-32BWSFN-160-SS	2.00	2.00	2.00	0.375	2.812	2.490	1.687	2.375
40P-40BWSF-160-SS	40P-40BWSFN-160-SS	2.50	2.50	2.31	0.375	3.312	2.995	2.125	2.875
48P-40BWSF-160-SS	48P-40BWSFN-160-SS	3.00	3.00	2.31	0.375	4.000	3.615	2.624	3.500

BUTT WELD FLANGE HEAD

FLANGES -
STAINLESS STEEL

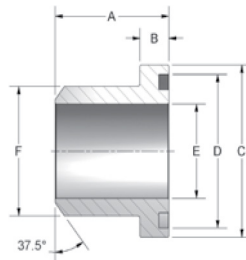

FIGURE 1

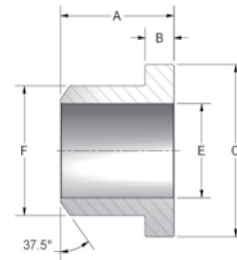

FIGURE 2

CODE 62 BUTT WELD TO FLANGE HEAD FOR SCHEDULE 80 PIPE

PART NO. O-RING FIG. 1	PART NO. FLAT FACE FIG. 2	PIPE SIZE	CLAMP SIZE	A	B	C	D	E	F
8P-8BWSFX-80-SS	8P-8BWSFXN-80-SS	0.50	0.50	1.10	0.305	1.250	1.000	0.548	0.840
12P-12BWSFX-80-SS	12P-12BWSFXN-80-SS	0.75	0.75	1.42	0.345	1.625	1.250	0.744	1.050
16P-16BWSFX-80-SS	16P-16BWSFXN-80-SS	1.00	1.00	1.61	0.375	1.875	1.560	0.959	1.315
20P-20BWSFX-80-SS	20P-20BWSFXN-80-SS	1.25	1.25	1.73	0.405	2.125	1.750	1.280	1.660
24P-24BWSFX-80-SS	24P-24BWSFXN-80-SS	1.50	1.50	2.17	0.495	2.500	2.115	1.502	1.900
32P-32BWSFX-80-SS	32P-32BWSFXN-80-SS	2.00	2.00	2.48	0.495	3.125	2.490	1.941	2.375

CODE 62 BUTT WELD TO FLANGE HEAD FOR SCHEDULE 160 PIPE

PART NO. O-RING FIG. 1	PART NO. FLAT FACE FIG. 2	PIPE SIZE	CLAMP SIZE	A	B	C	D	E	F
8P-8BWSFX-160-SS	8P-8BWSFXN-160-SS	0.50	0.50	1.10	0.305	1.250	1.000	0.464	0.840
12P-12BWSFX-160-SS	12P-12BWSFXN-160-SS	0.75	0.75	1.42	0.345	1.625	1.250	0.612	1.050
16P-16BWSFX-160-SS	16P-16BWSFXN-160-SS	1.00	1.00	1.61	0.375	1.875	1.560	0.815	1.315
20P-20BWSFX-160-SS	20P-20BWSFXN-160-SS	1.25	1.25	1.73	0.405	2.125	1.750	1.160	1.660
24P-24BWSFX-160-SS	24P-24BWSFXN-160-SS	1.50	1.50	2.17	0.495	2.500	2.115	1.338	1.900
32P-32BWSFX-160-SS	32P-32BWSFXN-160-SS	2.00	2.00	2.48	0.495	3.125	2.490	1.687	2.375

CODE 62 BUTT WELD TO FLANGE HEAD FOR SCHEDULE XXS PIPE

PART NO. O-RING FIG. 1	PART NO. FLAT FACE FIG. 2	PIPE SIZE	CLAMP SIZE	A	B	C	D	E	F
8P-8BWSFX-XXS-SS	8P-8BWSFXN-XXS-SS	0.50	0.50	1.10	0.305	1.250	1.000	0.252	0.840
12P-12BWSFX-XXS-SS	12P-12BWSFXN-XXS-SS	0.75	0.75	1.42	0.345	1.625	1.250	0.434	1.050
16P-16BWSFX-XXS-SS	16P-16BWSFXN-XXS-SS	1.00	1.00	1.61	0.375	1.875	1.560	0.599	1.315
20P-20BWSFX-XXS-SS	20P-20BWSFXN-XXS-SS	1.25	1.25	1.73	0.405	2.125	1.750	0.896	1.660
24P-24BWSFX-XXS-SS	24P-24BWSFXN-XXS-SS	1.50	1.50	2.17	0.495	2.500	2.115	1.100	1.900
32P-32BWSFX-XXS-SS	32P-32BWSFXN-XXS-SS	2.00	2.00	2.48	0.495	3.125	2.490	1.503	2.375

ELBOW BLOCK

FLANGES -
STAINLESS STEEL

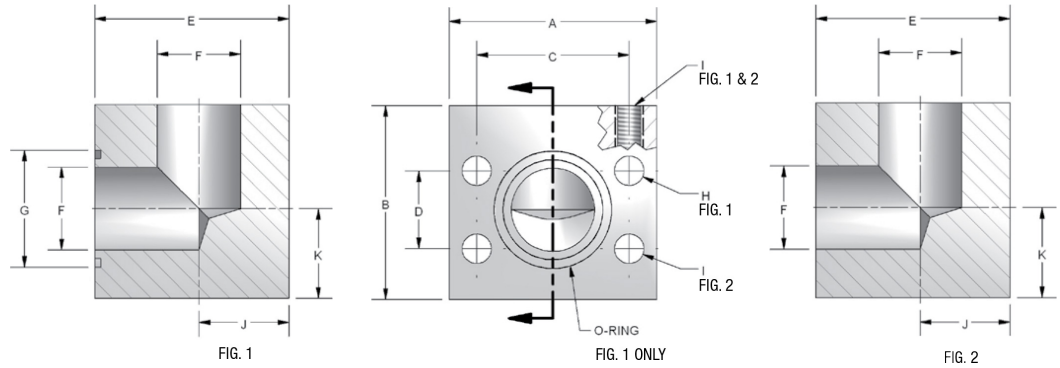

- Mounting kit available on o-ring grooved flanges by simply adding suffix letter 'U' to part number.

CODE 61 ELBOW BLOCK

PART NO. O-RING FIG. 1	PART NO. FLAT FACE FIG. 2	PAD SIZE	A	B	C	D	E	F	G	H	I UNC-2B	J	K	MOUNTING HARDWARE	
														O-RING	SHCS
W14-12-SS	W15-12-SS	0.75	2.62	2.50	1.875	0.875	2.25	0.75	1.250	0.406	3/8-16	1.03	1.03	214	3/8-16X3.00
W14-16-SS	W15-16-SS	1.00	2.82	2.50	2.062	1.031	2.50	1.00	1.560	0.406	3/8-16	1.16	1.09	219	3/8-16X3.25
W14-20-SS	W15-20-SS	1.25	3.19	3.00	2.312	1.188	3.00	1.25	1.750	0.469	7/16-14	1.44	1.31	222	7/16-14X4.00
W14-24-SS	W15-24-SS	1.50	3.75	3.50	2.750	1.406	3.50	1.50	2.115	0.531	1/2-13	1.62	1.62	225	1/2-13X4.50
W14-32-SS	W15-32-SS	2.00	4.00	4.00	3.062	1.688	4.00	2.00	2.490	0.531	1/2-13	1.91	1.91	228	1/2-13X5.00

CODE 62 ELBOW BLOCK

PART NO. O-RING FIG. 1	PART NO. FLAT FACE FIG. 2	PAD SIZE	A	B	C	D	E	F	G	H	I UNC-2B	J	K	MOUNTING HARDWARE	
														O-RING	SHCS
W12-12-SS	W13-12-SS	0.75	2.82	2.50	2.000	0.937	2.50	0.750	1.250	0.406	3/8-16	1.19	1.06	214	3/8-16X3.50
W12-16-SS	W13-16-SS	1.00	3.19	3.00	2.250	1.093	3.00	1.00	1.560	0.469	7/16-14	1.38	1.38	219	7/16-14X4.00
W12-20-SS	W13-20-SS	1.25	3.75	3.50	2.625	1.250	3.50	1.25	1.750	0.531	1/2-13	1.62	1.41	222	1/2-13X4.50
W12-24-SS	W13-24-SS	1.50	4.50	4.00	3.125	1.437	4.00	1.50	2.115	0.656	5/8-11	1.88	1.75	225	5/8-11X5.00
W12-32-SS	W13-32-SS	2.00	5.25	5.00	3.812	1.75	5.00	2.00	2.490	0.781	3/4-10	2.25	2.50	228	3/4-10X6.00

TEE JUNCTION BLOCK

FLANGES -
STAINLESS STEEL

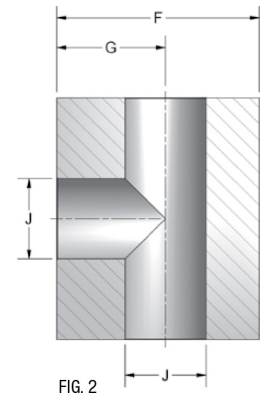
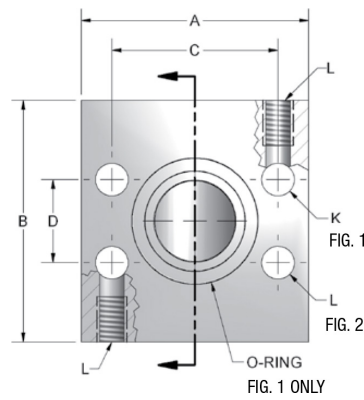
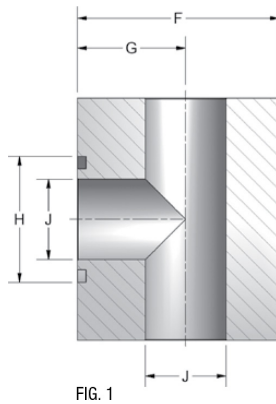

- Mounting kit available on o-ring grooved flanges by simply adding suffix letter 'U' to part number.

CODE 61 TEE JUNCTION BLOCK

PART NO. O-RING FIG. 1	PART NO. FLAT FACE FIG. 2	PAD SIZE	A	B	C	D	F	G	H	J	K	L UNC-2B	MOUNTING HARDWARE	
													O-RING	SHCS
W17-12-SS	W16-12-SS	0.75	2.62	2.75	1.875	0.875	2.25	1.22	1.250	0.75	0.406	3/8-16	214	3/8-16X3.00
W17-16-SS	W16-16-SS	1.00	2.82	3.00	2.062	1.031	2.50	1.34	1.560	1.00	0.406	3/8-16	219	3/8-16X3.25
W17-20-SS	W16-20-SS	1.25	3.19	3.50	2.312	1.188	3.00	1.56	1.750	1.25	0.492	7/16-14	222	7/16-14X4.00
W17-24-SS	W16-24-SS	1.50	3.75	4.00	2.750	1.406	3.50	1.88	2.115	1.50	0.531	1/2-13	225	1/2-13X4.50
W17-32-SS	W16-32-SS	2.00	4.00	4.25	3.062	1.688	4.00	2.09	2.490	2.00	0.531	1/2-13	228	1/2-13X5.00

CODE 62 TEE JUNCTION BLOCK

PART NO. O-RING FIG. 1	PART NO. FLAT FACE FIG. 2	PAD SIZE	A	B	C	D	E	F	G	H	J	K	L UNC-2B	MOUNTING HARDWARE	
														O-RING	SHCS
W19-12-SS	W18-12-SS	0.75	2.81	3.00	2.000	0.937	1.50	2.50	1.310	1.250	0.750	0.406	3/8-16	214	3/8-16X3.25
W19-16-SS	W18-16-SS	1.00	3.19	3.50	2.250	1.093	1.75	3.00	1.620	1.560	1.000	0.492	7/16-14	219	7/16-14X4.00
W19-20-SS	W18-20-SS	1.25	3.75	4.00	2.625	1.250	2.00	3.50	1.880	1.750	1.250	0.531	1/2-13	222	1/2-13X4.50
W19-24-SS	W18-24-SS	1.50	4.50	4.50	3.125	1.437	2.25	4.00	2.120	2.115	1.500	0.656	5/8-11	225	5/8-11X5.00
W19-32-SS	W18-32-SS	2.00	5.25	5.00	3.812	1.750	2.50	5.00	2.750	2.490	2.00	0.781	3/4-10	228	3/4-10X6.00

SOCKET WELD PIPE ELBOW

FLANGES -
STAINLESS STEEL

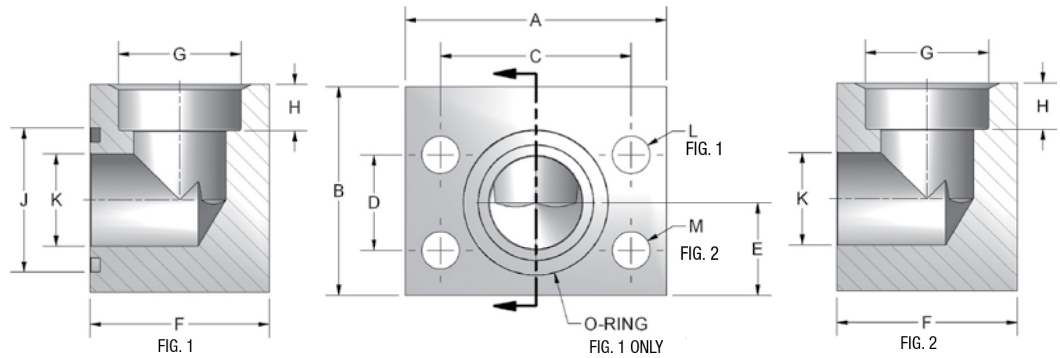

- Mounting kit available on o-ring grooved flanges by simply adding suffix letter 'U' to part number.

CODE 61 ELBOW SOCKET WELD - PIPE

PART NO. O-RING FIG. 1	PART NO. FLAT FACE FIG. 2	PIPE SIZE	PAD SIZE	A	B	C	D	E	F	G	H	J	K	L	M UNC-2B	MOUNTING HARDWARE	
																O-RING	SHCS
W176-8-8-SS	W169-8-8-SS	0.50	0.50	2.12	1.75	1.500	0.688	0.75	1.44	0.855	0.380	1.000	0.50	0.344	5/16-18	210	5/16-18X2.00
W176-12-12-SS	W169-12-12-SS	0.75	0.75	2.62	2.00	1.875	0.875	0.88	1.70	1.062	0.500	1.250	0.75	0.406	3/8-16	214	3/8-16X2.50
W176-16-16-SS	W169-16-16-SS	1.00	1.00	2.82	2.25	2.062	1.031	1.00	1.94	1.328	0.500	1.560	1.00	0.406	3/8-16	219	3/8-16X2.75
W176-20-20-SS	W169-20-20-SS	1.25	1.25	3.19	2.75	2.312	1.188	1.25	2.40	1.672	0.500	1.750	1.25	0.469	7/16-14	222	7/16-14X3.00
W176-24-24-SS	W169-24-24-SS	1.50	1.50	3.75	3.00	2.750	1.406	1.38	2.90	1.922	0.500	2.115	1.50	0.531	1/2-13	225	1/2-13X4.00
W176-32-32-SS	W169-32-32-SS	2.00	2.00	4.00	3.50	3.062	1.688	1.62	3.40	2.406	0.500	2.490	2.00	0.531	1/2-13	228	1/2-13X4.50
W176-40-40-SS	W169-40-40-SS	2.50	2.50	4.50	4.00	3.500	2.000	2.00	3.96	2.906	0.500	2.995	2.50	0.531	1/2-13	232	1/2-13X5.00
W176-48-48-SS	W169-48-48-SS	3.00	3.00	5.31	5.00	4.188	2.438	2.25	4.96	3.547	0.625	3.615	3.00	0.656	5/8-11	237	5/8-11X6.00

CODE 62 ELBOW SOCKET WELD - PIPE

PART NO. O-RING FIG. 1	PART NO. FLAT FACE FIG. 2	PIPE SIZE	PAD SIZE	A	B	C	D	E	F	G	H	J	K	L	M UNC-2B	MOUNTING HARDWARE	
																O-RING	SHCS
W186-8-8-SS	W189-8-8-SS	0.50	0.50	2.22	2.00	1.594	0.718	0.88	1.46	0.860	0.380	1.000	0.50	0.344	5/16-18	210	5/16-18X2.25
W186-12-12-SS	W189-12-12-SS	0.75	0.75	2.81	2.25	2.000	0.937	1.00	1.70	1.062	0.500	1.250	0.75	0.406	3/8-16	214	3/8-16X2.50
W186-16-16-SS	W189-16-16-SS	1.00	1.00	3.19	2.50	2.250	1.093	1.12	2.21	1.328	0.500	1.560	1.00	0.492	7/16-14	219	7/16-14X3.25
W186-20-20-SS	W189-20-20-SS	1.25	1.25	3.75	3.00	2.625	1.250	1.38	2.44	1.672	0.500	1.750	1.25	0.531	1/2-13	222	1/2-13X3.25
W186-24-24-SS	W189-24-24-SS	1.50	1.50	4.50	3.50	3.125	1.437	1.62	2.96	1.922	0.500	2.115	1.50	0.656	5/8-11	225	5/8-11X4.00
W186-32-32-SS	W189-32-32-SS	2.00	2.00	5.25	4.00	3.812	1.750	2.00	3.46	2.406	0.500	2.490	2.00	0.781	3/4-10	228	3/4-10X5.00

3000 SERIES SQUARE PATTERN

FLANGES -
STAINLESS STEEL

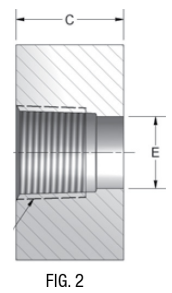
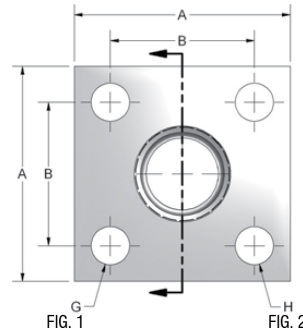
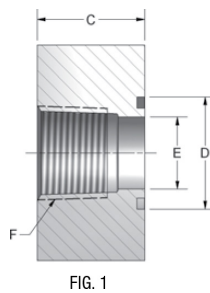
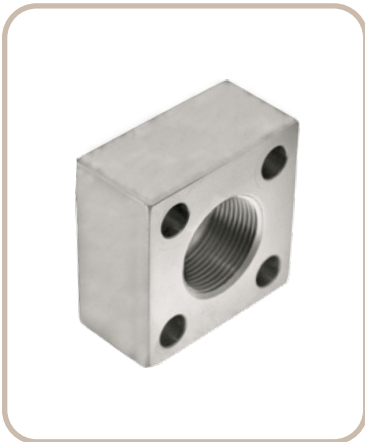

- Mounting kit available on o-ring grooved flanges by simply adding suffix letter 'U' to part number.

3000 SERIES SQUARE NPTF THREAD

PART NO. O-RING FIG. 1	PART NO. FLAT FACE FIG. 2	PAD SIZE	A	B	C	D	E	F	G	H UNC-2B	MOUNTING HARDWARE	
											O-RING	SHCS
W65-12-SS	W75-12-SS	0.75	2.25	1.438	1.25	1.375	0.752	0.75	0.406	3/8-16	216	3/8-16X2.00
W65-16-SS	W75-16-SS	1.00	3.00	2.000	1.50	1.750	1.002	1.00	0.531	1/2-13	222	1/2-13X2.25
W65-20-SS	W75-20-SS	1.25	3.00	2.000	1.50	1.750	1.252	1.25	0.531	1/2-13	222	1/2-13X2.25
W65-24-SS	W75-24-SS	1.50	4.00	2.750	1.75	2.500	1.502	1.50	0.656	5/8-11	228	5/8-11X2.75
W65-32-SS	W75-32-SS	2.00	4.00	2.750	1.75	2.500	2.002	2.00	0.656	5/8-11	228	5/8-11X2.75
W65-40-SS	W75-40-SS	2.50	5.50	3.750	2.25	3.500	2.502	2.50	0.906	7/8-9	236	7/8-9X3.50
W65-48-SS	W75-48-SS	3.00	5.50	3.750	2.25	3.500	3.002	3.00	0.906	7/8-9	236	7/8-9X3.50

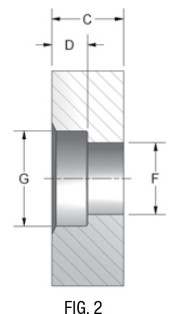
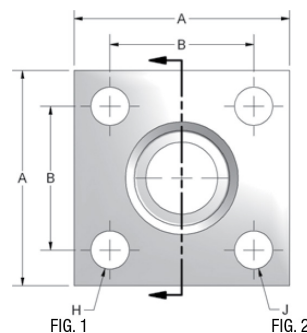
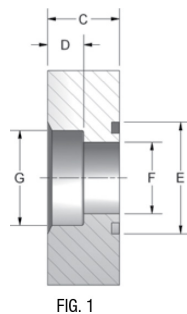

- Mounting kit available on o-ring grooved flanges by simply adding suffix letter 'U' to part number.

3000 SERIES SQUARE SOCKET WELD - PIPE

PART NO. O-RING FIG. 1	PART NO. FLAT FACE FIG. 2	PAD SIZE	A	B	C	D	E	F	G	H	J UNC-2B	MOUNTING HARDWARE	
												O-RING	SHCS
W66-12-SS	W76-12-SS	0.75	2.25	1.438	1.00	0.50	1.375	0.752	1.062	0.406	3/8-16	216	3/8-16X1.75
W66-16-SS	W76-16-SS	1.00	3.00	2.000	1.00	0.50	1.750	1.002	1.328	0.531	1/2-13	222	1/2-13X1.75
W66-20-SS	W76-20-SS	1.25	3.00	2.000	1.00	0.50	1.750	1.252	1.672	0.531	1/2-13	222	1/2-13X1.75
W66-24-SS	W76-24-SS	1.50	4.00	2.750	1.25	0.62	2.500	1.502	1.922	0.656	5/8-11	228	5/8-11X2.25
W66-32-SS	W76-32-SS	2.00	4.00	2.750	1.25	0.62	2.500	2.002	2.406	0.656	5/8-11	228	5/8-11X2.25
W66-40-SS	W76-40-SS	2.50	5.50	3.750	1.50	0.75	3.500	2.502	2.906	0.906	7/8-9	236	7/8-9X2.75
W66-48-SS	W76-48-SS	3.00	5.50	3.750	1.50	0.75	3.500	3.002	3.547	0.906	7/8-9	236	7/8-9X2.75
W66-64-SS	W76-64-SS	4.00	7.00	5.000	2.00	0.75	4.625	3.880	4.550	1.060	1-8	347	1-8X4.00



 905-545-2038 

 716-283-8781 

 www.trilexfluidpower.com

 wbisson@trilexfluidpower.com