

- 1 - Cover
- 2 - Indicator
- 3 - Tube
- 4 - O-Ring (13.0 I.D. x 2.6 c.s.d.)
- 5 - End piece
- 6 - Bolt M12
- 7 - O-Ring (13.0 I.D. x 3.0 c.s.d.)
- 8 - Nut (Flanged and serrated)
- 9 - Washer (27 O.D. 13.0 I.D. x 3 t)
- 10 - Tank Wall
- 11 - Thermometer (optional)

SLG-3T & SLG-5T

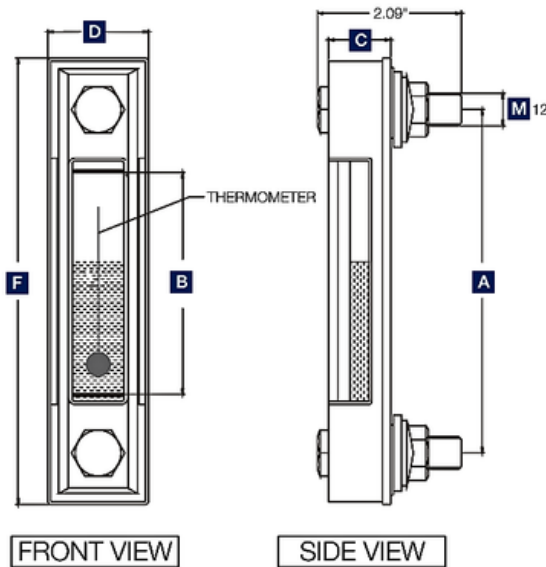

SLG-10T

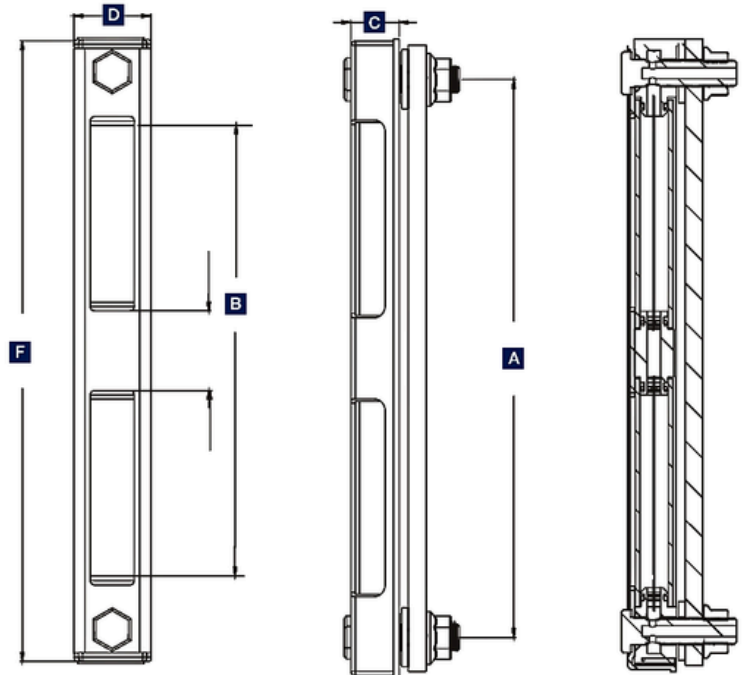

SPECIFICATIONS

- O-Ring type construction / sturdy die-cast cover
- 3 sizes: 3", 5" and 10" between bolt centers
- For non-pressurized tanks only
- Can be mounted on tapped holes
- Suitable for mineral / petroleum-based oils
- Maximum temperature: 176°F

GENERAL DIMENSIONS

PART NUMBER	A (in)	B (in)	C (in)	D (in)	F (in)	Wt (lbs)
SLG-3T	3.00	1.26	0.91	1.38	4.37	0.51
SLG-5T	5.00	2.99	0.91	1.38	6.38	0.57
SLG-10T	10.00	7.87	0.91	1.38	11.38	0.79